

# Air flow regulators

## Constant air flow regulator RM

### Application

- Maintains constant airflow in ventilation systems.
- Application for supply as well as exhaust system
- Temperature range: -10 °C to 60 °C
- Differential pressure range:
  - 50 to 250 Pa for standard version
  - 150 to 600 Pa for high pressure version

### Product design and material

1. Regulating membrane in silicone
2. Housing in PC / ABS plastic
3. Double-lip seal in elastomer



### Dimensions (mm) and weight (kg)

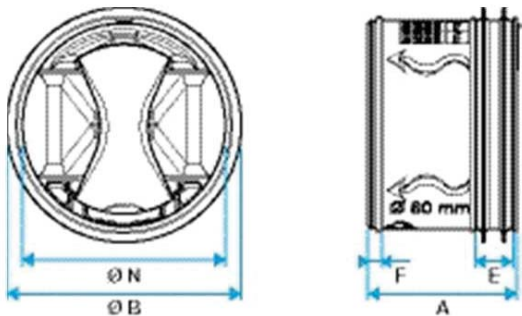

Φ Duct	Φ N	Φ B	A	E	F	Weight (kg)
80	76	85	53	14	2	0.06
100	92	105	61	14	2	0.10
125	116	132	61	14	2	0.13
125	116	132	97	14	2	0.15
150	147	153	103	14	2	0,35
160	153	167	103	14	2	0,35
200	190	210	130	20	2	0.57
250	238	262	159	20	2	1.00

### Air flow

Operating pressure range is 50 – 250 Pa for standard version and 150 – 600 Pa for high pressure.

Airflow accuracy:

- +/- 5 m<sup>3</sup>/h for airflow ≤ 50 m<sup>3</sup>/h,
- +/- 10% for airflow > 50 m<sup>3</sup>/h.

Fire rated M1.

Φ Duct	Airflow min* [m <sup>3</sup> /h]	Airflow max* [m <sup>3</sup> /h]
80	15	60
100	15	90
125	15	90
125	95	190
150/160	110	250
200	200	400
250	300	650

## Air flow range

RM

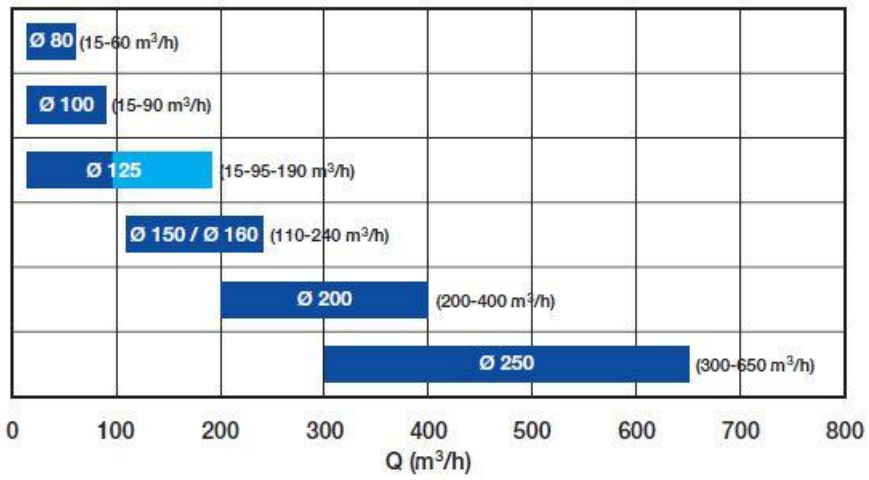

RM

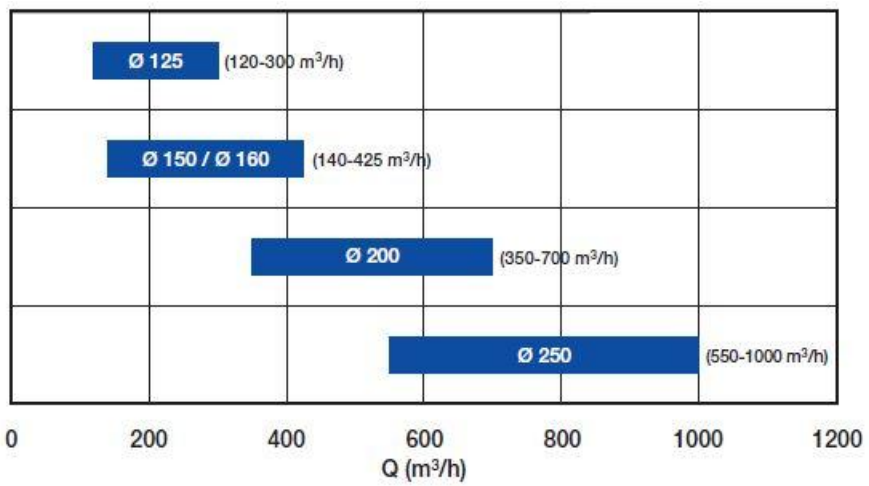

## Sound power levels of noise (Lw) at duct output

The following tables give the sound power levels of noise (Lw) expressed in decibels per octave (dB/oct) as well as the global sound power levels in dB(A) according to the pressure drop. These sound power levels are results of tests carried out by a Dutch independent laboratory (PEUTZ) and are given at the duct outlet. Measures were carried out in accordance with NF EN ISO 3741 and NF EN ISO 5135 norms, with a CAR fitted into a duct with an upstream and downstream straight length equal to 3 diameters. Operating pressure range is 50–250 Pa.

Ø 80		Differential Pressure $\Delta P$ (Pa)																														
Airflow (m <sup>3</sup> /h)		50 Pa							100 Pa							150 Pa							200 Pa									
		125 Hz	250 Hz	500 Hz	1000 Hz	2000 Hz	4000 Hz	8000 Hz	Overall Lw (dB(A))	125 Hz	250 Hz	500 Hz	1000 Hz	2000 Hz	4000 Hz	8000 Hz	Overall Lw (dB(A))	125 Hz	250 Hz	500 Hz	1000 Hz	2000 Hz	4000 Hz	8000 Hz	Overall Lw (dB(A))	125 Hz	250 Hz	500 Hz	1000 Hz	2000 Hz	4000 Hz	8000 Hz
15	25	21	21	15	14	9	6	23	25	30	30	27	28	23	19	34	25	32	34	34	34	31	25	40	26	34	38	40	40	37	31	45
20	25	22	22	16	15	9	6	24	26	31	31	28	28	24	19	34	26	34	35	34	35	31	26	40	27	36	38	40	40	38	32	46
25	25	23	23	17	15	10	7	24	26	32	31	28	29	24	19	35	27	35	35	34	35	32	26	41	28	37	39	40	41	38	33	46
30	25	24	23	18	16	10	7	25	27	32	32	29	29	25	19	36	28	36	36	35	36	32	27	41	29	39	40	40	41	38	33	46
35	25	25	24	18	17	11	7	25	27	33	32	29	30	25	20	36	28	37	37	35	36	32	27	42	30	41	40	40	42	39	34	47
40	25	25	24	19	18	11	8	26	28	34	33	30	30	26	20	36	29	38	37	35	37	33	28	42	31	42	41	40	42	39	35	47
45	25	26	25	20	18	12	8	27	28	35	33	30	31	26	20	37	30	39	38	36	37	33	28	43	32	44	42	40	43	39	36	48
50	25	27	26	21	19	12	8	27	29	35	33	31	32	27	20	37	31	41	38	36	38	34	29	43	33	45	43	40	43	40	36	48
60	25	29	27	23	20	13	9	29	30	37	34	32	33	28	21	39	33	43	40	36	39	35	30	44	36	49	44	41	44	41	38	49

Ø100		Differential Pressure $\Delta P$ (Pa)																														
Airflow (m <sup>3</sup> /h)		50 Pa							100 Pa							150 Pa							200 Pa									
		125 Hz	250 Hz	500 Hz	1000 Hz	2000 Hz	4000 Hz	8000 Hz	Overall Lw (dB(A))	125 Hz	250 Hz	500 Hz	1000 Hz	2000 Hz	4000 Hz	8000 Hz	Overall Lw (dB(A))	125 Hz	250 Hz	500 Hz	1000 Hz	2000 Hz	4000 Hz	8000 Hz	Overall Lw (dB(A))	125 Hz	250 Hz	500 Hz	1000 Hz	2000 Hz	4000 Hz	8000 Hz
15	30	27	25	19	15	7	7	26	29	28	31	30	28	22	20	35	29	32	34	36	37	33	32	42	31	36	37	41	45	44	45	51
20	29	27	25	19	15	7	7	26	29	28	31	30	28	23	20	35	29	33	34	36	37	33	32	42	31	37	38	41	45	43	44	50
25	28	27	25	19	16	8	7	26	28	29	32	30	28	23	20	35	29	33	35	36	37	33	31	42	32	37	38	41	45	43	43	50
30	27	27	25	19	16	8	7	27	28	30	32	30	29	24	20	35	30	34	35	36	37	33	31	42	32	37	39	41	44	42	41	49
35	26	27	25	20	16	8	7	27	28	30	32	30	29	24	20	36	30	34	36	36	37	33	30	42	32	38	39	41	44	42	40	49
40	25	27	25	20	17	8	7	27	28	31	33	30	30	25	20	36	30	35	36	36	37	33	30	42	33	38	40	41	44	41	39	49
50	22	27	26	20	18	9	7	27	28	33	34	30	31	26	21	37	31	36	38	36	37	34	28	43	34	40	42	41	43	41	35	48
55	23	27	26	20	17	9	7	27	28	32	33	30	31	26	20	37	31	36	37	36	37	34	29	43	34	39	41	41	43	41	36	48
60	22	27	26	20	18	9	7	27	28	34	34	30	32	27	21	38	31	37	39	36	37	34	28	43	34	40	43	41	43	41	34	48
65	23	28	26	21	19	10	8	28	29	34	34	31	32	27	21	38	32	38	39	36	38	34	28	43	35	41	43	42	43	41	34	48
70	25	28	26	21	19	10	9	28	29	35	35	31	32	27	20	38	33	39	39	37	38	35	27	43	36	42	43	42	43	41	34	49
75	26	29	26	22	20	11	10	28	30	36	35	31	33	28	20	38	34	40	40	37	38	35	27	44	37	43	44	42	43	41	34	49
85	29	30	27	23	22	13	13	30	32	38	35	32	33	29	20	39	36	42	40	37	39	35	27	44	39	46	45	42	44	41	34	49
90	31	30	27	24	22	13	14	30	33	39	36	32	34	29	19	40	37	43	41	37	39	36	27	45	40	47	45	42	44	41	34	50

Ø 125		Differential Pressure $\Delta P$ (Pa)																														
Airflow (m <sup>3</sup> /h)		50 Pa							100 Pa							150 Pa							200 Pa									
		125 Hz	250 Hz	500 Hz	1000 Hz	2000 Hz	4000 Hz	8000 Hz	Overall Lw (dB(A))	125 Hz	250 Hz	500 Hz	1000 Hz	2000 Hz	4000 Hz	8000 Hz	Overall Lw (dB(A))	125 Hz	250 Hz	500 Hz	1000 Hz	2000 Hz	4000 Hz	8000 Hz	Overall Lw (dB(A))	125 Hz	250 Hz	500 Hz	1000 Hz	2000 Hz	4000 Hz	8000 Hz
15	24	30	27	20	15	6	13	28	27	33	36	33	31	24	21	38	29	34	38	37	35	30	29	42	31	34	40	40	39	36	36	46
25	25	30	28	21	16	7	14	28	28	33	35	33	31	24	21	38	30	34	38	37	35	30	28	42	31	35	40	40	39	37	35	46
30	25	30	28	21	16	8	14	28	28	33	35	33	31	24	21	38	30	34	38	37	35	31	28	42	32	35	40	40	39	37	34	46
45	26	31	28	23	17	9	14	29	29	33	35	33	32	23	20	38	31	35	38	37	36	31	27	42	33	37	41	40	39	38	33	46
50	27	31	28	23	18	10	14	29	29	34	35	34	32	23	19	38	31	35	38	37	36	31	26	42	33	37	41	40	40	38	33	46
60	28	31	28	24	19	11	14	30	30	34	35	34	33	23	19	39	32	36	38	37	36	32	25	42	34	38	41	40	40	39	32	46
65	29	31	28	25	19	11	14	30	30	34	34	34	33	23	19	39	32	36	38	37	37	32	25	42	34	39	41	40	40	39	31	46
70	29	31	28	25	20	12	14	30	31	34	34	34	33	23	18	39	33	37	38	37	37	32	25	42	35	39	41	40	41	40	31	47
75	30	31	28	26	20	12	14	30	31	34	34	34	34	23	18	39	33	37	38	37	37	32	24	43	35	39	41	40	41	40	31	47
80	31	31	28	26	20	13	14	31	31	34	34	34	34	23	18	39	33	37	38	37	37	32	24	43	35	40	41	41	42	41	30	47
85	31	31	28	26	21	13	15	31	32	34	34	34	34	23	18	39	34	37	38	37	38	33	24	43	36	40	41	41	43	41	30	48
90	32	31	29	27	21	14	15	31	32	34	34	34	35	23	17	39	34	38	38	38	38	33	23	43	36	41	41	41	43	42	29	48
95	32	32	29	28	22	14	15	32	32	34	34	34	35	23	17	40	35	38	38	38	38	33	23	43	37	41	41	41	44	42	29	49

Ø 125		Differential Pressure $\Delta P$ (Pa)																															
		50 Pa								100 Pa								150 Pa								200 Pa							
Airflow (m <sup>3</sup> /h)		125 Hz	250 Hz	500 Hz	1000 Hz	2000 Hz	4000 Hz	8000 Hz	Overall Lw (dB(A))	125 Hz	250 Hz	500 Hz	1000 Hz	2000 Hz	4000 Hz	8000 Hz	Overall Lw (dB(A))	125 Hz	250 Hz	500 Hz	1000 Hz	2000 Hz	4000 Hz	8000 Hz	Overall Lw (dB(A))	125 Hz	250 Hz	500 Hz	1000 Hz	2000 Hz	4000 Hz	8000 Hz	Overall Lw (dB(A))
		100		31	33	30	25	15	11	15	31	36	39	40	37	29	25	19	41	39	41	44	43	35	32	26	47	42	43	48	49	41	38
110		32	33	30	26	16	12	15	31	38	40	40	37	30	26	20	41	41	43	45	43	36	33	27	47	45	45	49	49	42	39	33	52
120		33	33	30	26	17	13	15	31	40	41	40	38	32	27	21	42	44	44	45	44	38	34	28	47	48	47	50	49	43	40	35	53
130		34	33	30	27	18	14	16	32	42	41	40	38	33	28	22	42	47	46	45	44	39	35	29	48	51	49	50	50	44	41	36	53
140		36	33	30	27	20	15	16	32	44	42	40	39	34	29	23	43	49	47	46	45	40	36	30	49	54	52	51	50	45	43	37	54
150		37	33	30	28	21	16	17	32	47	43	40	40	36	30	24	44	52	49	46	45	41	37	32	50	57	54	51	51	47	44	39	55
160		38	33	30	28	22	16	17	33	49	43	40	40	37	31	24	45	55	50	47	46	43	38	33	51	60	56	52	51	48	45	40	56
190		42	34	31	29	25	19	19	35	56	46	40	43	41	33	27	48	63	55	48	49	46	41	36	54	69	63	54	54	51	48	44	61

Ø 160		Differential Pressure $\Delta P$ (Pa)																															
		50 Pa								100 Pa								150 Pa								200 Pa							
Airflow (m <sup>3</sup> /h)		125 Hz	250 Hz	500 Hz	1000 Hz	2000 Hz	4000 Hz	8000 Hz	Overall Lw (dB(A))	125 Hz	250 Hz	500 Hz	1000 Hz	2000 Hz	4000 Hz	8000 Hz	Overall Lw (dB(A))	125 Hz	250 Hz	500 Hz	1000 Hz	2000 Hz	4000 Hz	8000 Hz	Overall Lw (dB(A))	125 Hz	250 Hz	500 Hz	1000 Hz	2000 Hz	4000 Hz	8000 Hz	Overall Lw (dB(A))
		110		28	31	32	28	27	19	14	34	34	36	38	41	39	32	23	45	38	42	44	46	45	39	31	50	41	46	49	51	49	45
120		29	30	31	28	26	18	14	34	35	37	39	40	38	31	22	44	39	42	44	46	44	38	30	50	43	47	49	50	49	44	38	56
130		29	30	31	27	25	17	13	33	36	37	39	39	38	30	22	43	40	43	44	45	43	37	30	49	44	47	49	50	48	44	38	56
140		29	30	30	26	23	15	13	32	36	38	39	38	37	30	22	43	41	43	45	44	42	37	30	49	46	48	50	49	47	43	38	56
150		29	30	30	26	22	14	13	32	37	38	39	38	36	29	21	42	43	44	45	44	41	36	30	48	47	49	50	49	46	43	38	56
160		29	30	29	25	21	12	13	31	38	39	39	37	35	28	21	42	44	44	45	43	41	35	30	48	49	49	50	49	46	42	38	57
170		30	29	29	25	20	11	13	31	39	39	39	37	34	27	21	42	45	45	45	43	40	35	30	48	50	50	50	49	45	42	38	57
180		30	29	28	24	19	10	13	31	39	40	39	36	33	26	20	41	46	46	45	43	39	34	30	48	52	50	51	49	44	41	39	58
190		30	29	29	24	19	10	13	30	40	40	39	36	33	26	21	41	46	46	45	43	39	34	30	47	52	51	51	48	44	41	38	58
200		30	30	29	24	19	10	13	30	40	40	40	36	33	26	21	41	47	46	46	43	39	34	29	48	52	51	51	48	44	41	37	58
210		30	30	29	24	19	10	13	30	41	40	40	36	33	26	21	42	47	46	46	43	39	34	29	48	52	51	51	48	45	41	36	58
240		30	31	29	24	18	10	14	30	42	41	40	37	33	26	21	42	48	46	46	42	40	34	28	48	53	51	51	47	45	41	35	59

Ø 200		Differential Pressure $\Delta P$ (Pa)																															
		50 Pa								100 Pa								150 Pa								200 Pa							
Airflow (m <sup>3</sup> /h)		125 Hz	250 Hz	500 Hz	1000 Hz	2000 Hz	4000 Hz	8000 Hz	Overall Lw (dB(A))	125 Hz	250 Hz	500 Hz	1000 Hz	2000 Hz	4000 Hz	8000 Hz	Overall Lw (dB(A))	125 Hz	250 Hz	500 Hz	1000 Hz	2000 Hz	4000 Hz	8000 Hz	Overall Lw (dB(A))	125 Hz	250 Hz	500 Hz	1000 Hz	2000 Hz	4000 Hz	8000 Hz	Overall Lw (dB(A))
		225		27	26	23	19	13	8	14	25	36	35	34	30	27	21	15	36	41	41	40	36	34	29	20	42	45	46	45	42	39	35
250		29	28	25	21	16	10	15	27	38	37	35	33	29	23	16	37	42	42	41	38	36	30	22	43	47	47	46	43	41	37	27	48
275		30	29	26	23	18	12	16	28	39	38	36	35	31	24	17	39	44	43	41	40	38	32	23	45	48	47	46	44	44	39	28	50
300		32	31	27	25	20	14	16	30	41	40	37	38	32	26	18	41	46	44	42	42	40	33	24	46	51	48	47	46	46	40	30	51
325		33	33	29	27	21	15	16	32	42	41	38	39	34	28	20	42	46	46	44	43	41	35	26	48	50	50	49	47	47	41	31	53
350		35	34	30	29	23	17	17	33	44	43	39	40	35	29	23	44	47	47	45	44	42	36	27	49	50	51	51	48	48	42	32	54
400		38	37	33	33	27	20	17	37	46	46	42	43	38	33	27	47	48	50	48	47	44	38	31	52	50	55	54	51	49	43	34	56

Ø 250		Differential Pressure $\Delta P$ (Pa)																															
		50 Pa								100 Pa								150 Pa								200 Pa							
Airflow (m <sup>3</sup> /h)		125 Hz	250 Hz	500 Hz	1000 Hz	2000 Hz	4000 Hz	8000 Hz	Overall Lw (dB(A))	125 Hz	250 Hz	500 Hz	1000 Hz	2000 Hz	4000 Hz	8000 Hz	Overall Lw (dB(A))	125 Hz	250 Hz	500 Hz	1000 Hz	2000 Hz	4000 Hz	8000 Hz	Overall Lw (dB(A))	125 Hz	250 Hz	500 Hz	1000 Hz	2000 Hz	4000 Hz	8000 Hz	Overall Lw (dB(A))
		300		34	30	24	17	19	12	13	28	47	41	36	36	32	26	20	41	53	47	42	33	37	34	27	45	60	51	48	32	41	40
350		35	31	26	21	20	13	13	29	48	42	38	38	33	27	21	42	52	47	43	37	38	34	28	46	57	51	49	37	43	40	34	51
400		36	32	28	25	21	13	13	31	48	43	39	40	34	28	21	43	51	47	45	41	40	35	28	48	54	52	50	43	45	41	34	52
450		36	33	31	29	21	14	13	33	49	43	41	42	35	28	21	45	50	48	47	45	41	35	28	50	52	52	52	49	47	42	34	54
500		37	34	33	35	22	14	13	37	49	44	43	44	35	29	22	47	49	48	49	50	43	36	28	53	49	53	55	55	50	42	34	54
550		38	35	34	35	23	16	14	37	49	45	44	45	37	30	22	48	50	49	49	50	44	36	29	53	51	53	54	54	49	42	35	57
650		40	36	36	36	26	18	14	39	48	46	46	47	40	32	22	50	50	50	50	50	44	37	30	53	53	53	54	53	48	41	36	57

## Constant airflow regulator RMV

### Application

- Maintains constant airflow in ventilation system.
- New product range: 1 size covers several airflow.
- Application for supply as well as exhaust system
- Temperature range: -10 °C to 60 °C
- Differential pressure range 50 to 250 Pa
- Airflow adjustment thanks to a rotative ring (Patented)



### Product design and material

1. Regulating membrane in silicone
2. Housing in PC / ABS plastic
3. Removable insert in PC / ABS plastic
4. Double-lip seal in elastomere
5. Rotative ring in PC / ABS plastic for airflow setting

### Dimensions (mm) and weight (kg)

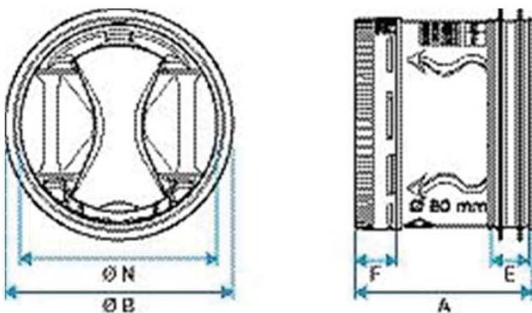

Φ Duct	Φ N	Φ B	A	E	F	Weight (kg)
80	76	85	65	14	2	0.08
100	92	105	70	14	2	0.12
125	116	132	70	14	2	0.15
125	116	132	110	14	2	0.17
150	147	153	118	14	2	0,37
160	153	167	118	14	2	0,37
200	190	210	145	20	2	0.59
250	238	262	180	20	2	1.02

### Airflow

Operating pressure range is 50 – 250 Pa.

Airflow accuracy:

- +/- 5 m<sup>3</sup>/h for airflow ≤ 50 m<sup>3</sup>/h,
- +/- 10% for airflow > 50 m<sup>3</sup>/h.

Fire rated M1.

Φ Duct	Airflow min* [m <sup>3</sup> /h]	Airflow max* [m <sup>3</sup> /h]
80	15	65
100	20	90
125	20	95
125	100	180
150/160	100	240
200	200	400
250	300	650

**Installation**

- The MR is fitted directly into a circular duct, and in particular near a spigot or
- Direction of mounting indicated on the MR.
- Horizontal/vertical mounting.
- In air supply or exhaust, we recommend respecting a minimum distance of  $3 \varnothing$  between MR and the terminal (grille/ diffuser...) in order to avoid aeraulic or acoustic disturbances (see pictures).
- We also recommend respecting a minimum distance of  $3 \varnothing$  between the MR and a fitting (elbow joint, Te-branch, etc.).

**Air exhaust**

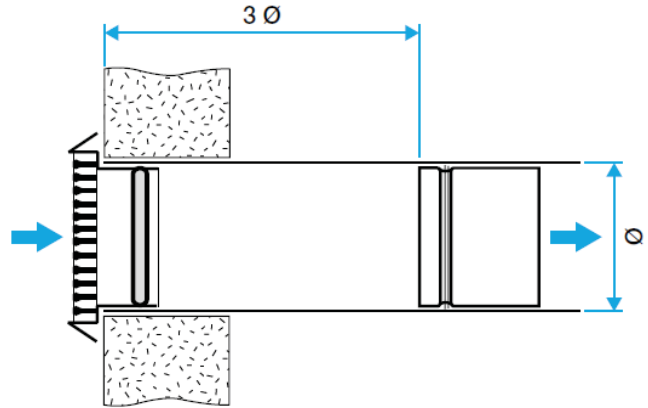

**Air supply**

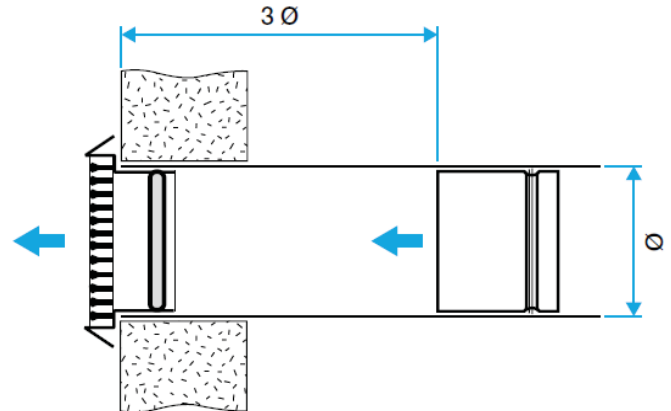

**Air flow range**

RMV

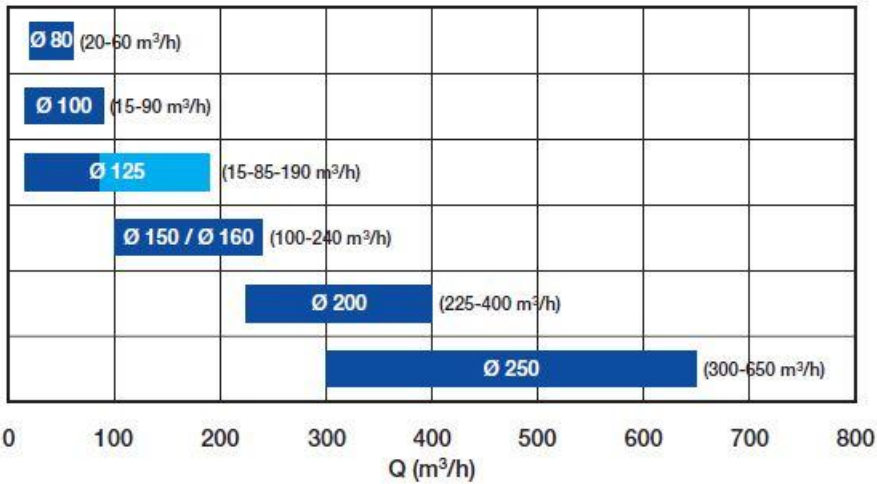

## Sound power levels of noise (Lw) at duct output

The following tables give the sound power levels of noise (Lw) expressed in decibels per octave (dB/oct) as well as the global sound power levels in dB(A) according to the pressure drop. These sound power levels are results of tests carried out by a Dutch independent laboratory (PEUTZ) and are given at the duct outlet. Measures were carried out in accordance with NF EN ISO 3741 and NF EN ISO 5135 norms, with a CAR fitted into a duct with an upstream and downstream straight length equal to 3 diameters. Operating pressure range is 50–250 Pa.

Ø 80	Differential Pressure $\Delta P$ (Pa)																															
	50 Pa								100 Pa								150 Pa								200 Pa							
	125 Hz	250 Hz	500 Hz	1000 Hz	2000 Hz	4000 Hz	8000 Hz	Overall Lw (dB(A))	125 Hz	250 Hz	500 Hz	1000 Hz	2000 Hz	4000 Hz	8000 Hz	Overall Lw (dB(A))	125 Hz	250 Hz	500 Hz	1000 Hz	2000 Hz	4000 Hz	8000 Hz	Overall Lw (dB(A))	125 Hz	250 Hz	500 Hz	1000 Hz	2000 Hz	4000 Hz	8000 Hz	Overall Lw (dB(A))
15	19	25	24	18	21	7	6	26	19	29	30	28	32	22	18	36	25	35	36	36	43	34	22	45	31	40	42	43	53	48	26	56
20	19	25	24	19	21	8	7	26	20	30	31	29	32	23	18	36	26	35	36	36	42	34	23	45	31	41	42	43	52	47	27	55
25	20	25	24	19	21	8	7	27	21	30	31	29	32	23	19	36	27	36	37	36	42	34	24	45	32	41	42	43	51	46	29	54
30	20	25	24	20	21	8	8	27	22	31	31	29	32	24	19	37	28	37	37	36	42	34	25	45	33	42	42	42	50	45	31	53
35	20	25	24	20	21	9	8	27	23	32	32	30	33	25	19	37	29	37	37	36	41	35	26	44	33	42	42	42	49	45	33	52
40	20	26	24	21	21	9	8	27	24	32	32	30	33	25	20	37	30	38	37	36	41	35	27	44	34	43	42	42	48	44	34	51
45	20	26	24	21	21	10	9	27	26	33	32	30	33	26	20	37	30	38	37	36	40	35	28	44	35	44	42	42	47	44	36	51
50	21	26	24	21	21	10	9	27	27	33	33	31	33	27	20	38	31	39	38	36	40	35	30	44	36	44	42	41	46	43	38	50
60	21	26	25	22	21	12	10	28	29	34	34	31	33	29	21	39	33	40	38	36	39	36	32	44	37	45	42	41	44	43	41	50

Ø 100	Differential Pressure $\Delta P$ (Pa)																															
	50 Pa								100 Pa								150 Pa								200 Pa							
	125 Hz	250 Hz	500 Hz	1000 Hz	2000 Hz	4000 Hz	8000 Hz	Overall Lw (dB(A))	125 Hz	250 Hz	500 Hz	1000 Hz	2000 Hz	4000 Hz	8000 Hz	Overall Lw (dB(A))	125 Hz	250 Hz	500 Hz	1000 Hz	2000 Hz	4000 Hz	8000 Hz	Overall Lw (dB(A))	125 Hz	250 Hz	500 Hz	1000 Hz	2000 Hz	4000 Hz	8000 Hz	Overall Lw (dB(A))
15	20	26	22	14	15	8	3	23	24	32	31	29	25	18	17	34	31	32	35	34	34	31	29	40	38	32	38	38	43	43	40	48
20	21	27	22	15	14	8	4	24	25	32	32	30	25	19	17	34	31	33	35	34	34	31	28	40	37	33	39	39	42	42	39	48
25	22	27	23	16	14	8	6	24	25	33	33	30	26	19	17	35	31	34	36	35	34	31	28	41	36	34	39	40	42	42	38	48
30	23	27	24	17	14	8	7	25	26	33	33	31	27	20	17	35	31	35	37	36	35	31	27	41	35	36	40	41	42	41	37	48
35	23	28	24	18	15	8	8	25	27	34	34	31	27	21	17	36	31	35	38	37	35	31	27	42	34	37	41	41	42	41	36	48
45	24	28	25	19	15	7	9	26	27	34	35	32	28	21	17	37	31	36	39	37	35	31	26	42	34	38	42	42	42	40	35	48
50	27	30	28	21	15	7	13	28	29	36	37	34	30	23	17	39	31	39	41	40	36	31	25	44	32	42	45	45	42	39	32	49
55	26	29	27	20	15	7	11	27	29	35	36	34	29	22	17	38	31	38	40	39	36	31	25	43	32	40	44	44	42	40	33	49
60	28	31	28	22	15	7	14	29	30	36	38	35	30	24	18	40	31	40	42	41	37	32	24	45	31	43	46	46	42	39	31	50
65	27	30	27	22	16	7	14	29	30	36	37	34	31	24	18	39	31	40	42	40	37	32	25	44	32	43	46	45	43	39	32	50
70	26	29	27	22	16	8	14	28	30	36	37	34	31	24	18	39	32	40	41	39	38	33	25	44	33	44	45	44	43	40	32	49
75	26	28	26	21	17	8	14	28	30	36	36	33	32	25	18	39	32	41	41	39	38	33	26	44	34	45	45	44	44	41	33	50
80	24	27	24	21	18	9	14	27	30	37	35	32	33	26	18	38	33	42	40	38	40	34	27	45	36	46	44	42	46	42	35	50
90	23	26	24	20	18	10	14	27	31	37	34	32	34	26	18	39	34	42	39	37	40	35	27	45	37	47	44	42	47	42	35	51

Ø 125	Differential Pressure $\Delta P$ (Pa)																															
	50 Pa								100 Pa								150 Pa								200 Pa							
	125 Hz	250 Hz	500 Hz	1000 Hz	2000 Hz	4000 Hz	8000 Hz	Overall Lw (dB(A))	125 Hz	250 Hz	500 Hz	1000 Hz	2000 Hz	4000 Hz	8000 Hz	Overall Lw (dB(A))	125 Hz	250 Hz	500 Hz	1000 Hz	2000 Hz	4000 Hz	8000 Hz	Overall Lw (dB(A))	125 Hz	250 Hz	500 Hz	1000 Hz	2000 Hz	4000 Hz	8000 Hz	Overall Lw (dB(A))
15	32	23	22	19	16	4	2	24	29	29	28	28	33	15	15	36	31	31	32	31	36	26	24	39	33	32	35	34	47	37	32	49
25	32	25	23	20	17	5	5	26	31	31	30	29	33	17	15	36	33	33	34	33	36	28	24	40	35	35	38	37	45	37	32	47
30	32	26	24	21	17	6	6	26	32	32	31	30	32	18	15	37	34	34	36	34	36	28	24	41	35	36	39	38	43	37	32	47
45	33	29	26	22	19	8	10	28	34	35	35	32	32	21	16	38	36	38	39	37	37	30	24	43	37	41	44	42	42	37	31	48
50	33	30	27	23	19	9	12	29	35	36	36	33	32	22	17	38	36	39	41	38	37	30	24	44	38	42	45	44	42	38	31	49
60	34	32	28	24	20	11	15	30	36	38	38	34	32	24	17	40	38	42	43	40	38	32	24	46	39	45	49	46	43	38	30	51
65	34	33	29	24	20	12	16	31	37	39	39	35	32	25	17	40	39	43	45	41	38	32	24	46	40	46	50	48	44	38	30	52
70	34	34	30	25	21	13	18	32	38	40	40	35	32	26	18	41	39	44	46	42	39	33	24	47	41	48	52	49	45	38	30	53
75	34	35	31	25	21	14	19	32	39	42	41	36	32	27	18	42	40	46	47	44	39	33	24	48	42	49	53	50	46	39	29	54
80	35	36	31	26	22	14	20	33	39	43	43	37	32	29	18	43	41	47	49	45	39	34	24	49	42	51	55	52	47	39	29	56
85	35	37	32	27	22	15	22	34	40	44	44	37	32	30	19	44	42	48	50	46	40	34	24	50	43	52	56	53	48	39	29	57
90	35	38	33	27	23	16	23	35	41	45	45	38	32	31	19	45	42	49	51	47	40	35	24	51	44	54	58	54	48	39	29	59
95	36	39	34	28	23	17	25	36	42	46	46	39	33	32	19	46	43	51	53	48	40	36	24	53	45	55	60	56	49	39	28	60

Ø 125		Differential Pressure $\Delta P$ (Pa)																														
Airflow (m <sup>3</sup> /h)	50 Pa								100 Pa								150 Pa								200 Pa							
	125 Hz	250 Hz	500 Hz	1000 Hz	2000 Hz	4000 Hz	8000 Hz	Overall Lw (dB(A))	125 Hz	250 Hz	500 Hz	1000 Hz	2000 Hz	4000 Hz	8000 Hz	Overall Lw (dB(A))	125 Hz	250 Hz	500 Hz	1000 Hz	2000 Hz	4000 Hz	8000 Hz	Overall Lw (dB(A))	125 Hz	250 Hz	500 Hz	1000 Hz	2000 Hz	4000 Hz	8000 Hz	Overall Lw (dB(A))
100	36	35	32	30	25	16	14	34	43	43	42	39	36	31	23	44	46	45	47	45	41	38	32	50	48	48	51	50	46	44	39	54
110	36	35	31	30	25	17	15	34	43	43	42	39	36	31	24	44	47	46	47	45	42	38	32	50	50	48	51	50	47	45	40	55
120	36	34	31	30	25	18	15	34	44	43	42	40	36	31	24	44	48	46	47	46	43	39	33	50	52	49	52	51	48	45	40	55
130	37	34	31	29	25	18	16	34	44	42	41	40	37	32	25	44	50	47	47	46	43	40	33	51	54	50	52	51	49	46	41	56
140	37	34	31	29	25	19	17	34	45	42	41	40	37	32	25	45	51	47	47	47	44	40	34	51	56	51	52	52	50	47	42	57
150	37	34	31	29	24	20	17	34	45	42	41	41	37	33	26	45	52	47	47	47	45	41	34	52	58	52	53	53	51	48	42	58
160	38	34	31	29	24	20	18	34	46	42	41	41	38	33	26	46	54	48	47	48	46	42	35	53	61	53	53	54	53	49	43	59
190	39	33	31	29	24	22	20	34	47	41	41	43	39	35	28	46	58	49	48	50	48	44	37	54	67	57	54	56	56	51	46	62

Ø 160		Differential Pressure $\Delta P$ (Pa)																														
Airflow (m <sup>3</sup> /h)	50 Pa								100 Pa								150 Pa								200 Pa							
	125 Hz	250 Hz	500 Hz	1000 Hz	2000 Hz	4000 Hz	8000 Hz	Overall Lw (dB(A))	125 Hz	250 Hz	500 Hz	1000 Hz	2000 Hz	4000 Hz	8000 Hz	Overall Lw (dB(A))	125 Hz	250 Hz	500 Hz	1000 Hz	2000 Hz	4000 Hz	8000 Hz	Overall Lw (dB(A))	125 Hz	250 Hz	500 Hz	1000 Hz	2000 Hz	4000 Hz	8000 Hz	Overall Lw (dB(A))
110	31	31	30	24	19	10	12	33	36	37	40	34	31	25	17	40	38	40	44	39	37	32	26	45	39	43	48	44	43	38	33	52
120	31	31	30	24	19	11	13	32	37	38	40	34	31	25	17	41	39	41	44	40	37	32	26	46	41	44	48	44	43	39	33	53
130	31	31	30	24	19	11	13	31	38	38	40	35	32	26	18	41	41	42	44	40	38	33	26	46	42	45	49	44	43	39	33	53
140	31	31	30	25	20	11	13	31	39	39	40	36	32	26	18	41	42	43	45	40	38	33	26	46	44	47	49	45	44	39	33	54
150	31	31	30	25	20	11	13	31	40	40	40	36	33	26	18	41	43	44	45	41	39	33	26	46	46	48	49	45	44	39	33	55
160	31	31	30	26	20	11	13	31	42	41	39	37	33	27	19	42	44	45	45	41	39	33	26	47	47	49	50	45	44	40	33	56
170	31	31	30	26	21	12	14	31	43	41	39	38	34	27	19	42	46	46	45	42	40	34	27	47	49	51	50	45	45	40	33	56
180	32	31	30	27	21	12	14	32	44	42	39	39	34	27	20	43	47	47	45	42	40	34	27	48	50	52	50	45	45	40	33	57
190	31	31	30	27	22	13	14	32	43	42	39	39	35	28	21	43	47	47	45	42	40	34	27	48	50	51	50	45	45	40	33	57
200	31	31	30	27	22	13	14	32	43	42	39	39	35	29	21	43	47	46	45	42	40	35	28	47	50	51	49	45	44	40	33	56
210	30	31	31	28	22	14	14	32	43	41	39	39	36	30	22	43	47	46	45	42	40	35	28	47	50	50	49	45	44	40	34	56
240	29	31	31	28	23	17	13	33	42	40	40	40	37	32	25	44	46	44	44	42	40	37	30	48	50	48	48	44	43	40	34	55

Ø 200		Differential Pressure $\Delta P$ (Pa)																														
Airflow (m <sup>3</sup> /h)	50 Pa								100 Pa								150 Pa								200 Pa							
	125 Hz	250 Hz	500 Hz	1000 Hz	2000 Hz	4000 Hz	8000 Hz	Overall Lw (dB(A))	125 Hz	250 Hz	500 Hz	1000 Hz	2000 Hz	4000 Hz	8000 Hz	Overall Lw (dB(A))	125 Hz	250 Hz	500 Hz	1000 Hz	2000 Hz	4000 Hz	8000 Hz	Overall Lw (dB(A))	125 Hz	250 Hz	500 Hz	1000 Hz	2000 Hz	4000 Hz	8000 Hz	Overall Lw (dB(A))
225	29	27	24	23	18	11	13	27	39	39	36	33	31	26	18	39	43	42	41	39	37	32	24	44	46	45	46	44	42	38	29	49
250	30	28	26	24	19	12	13	29	41	40	37	35	33	26	19	40	44	43	42	40	38	32	24	45	47	47	45	44	42	37	28	49
275	31	30	27	26	20	13	13	30	42	41	38	38	34	27	20	42	46	45	42	41	38	32	24	45	49	48	45	44	42	36	27	49
300	32	32	29	27	21	14	14	31	44	41	39	40	36	28	21	44	47	46	42	42	39	32	23	46	50	50	45	44	42	35	26	49
325	34	33	30	29	23	16	14	33	45	42	40	41	37	30	23	44	48	47	44	43	40	34	26	48	49	51	48	45	44	38	28	51
350	36	34	31	31	25	18	15	35	46	43	40	42	37	31	25	45	49	48	46	44	42	36	28	49	52	53	52	47	46	40	31	53
400	39	37	34	35	28	21	17	38	48	45	42	43	39	34	28	47	51	51	50	47	45	40	32	53	55	57	59	50	50	44	36	58

Ø 250		Differential Pressure $\Delta P$ (Pa)																														
Airflow (m <sup>3</sup> /h)	50 Pa								100 Pa								150 Pa								200 Pa							
	125 Hz	250 Hz	500 Hz	1000 Hz	2000 Hz	4000 Hz	8000 Hz	Overall Lw (dB(A))	125 Hz	250 Hz	500 Hz	1000 Hz	2000 Hz	4000 Hz	8000 Hz	Overall Lw (dB(A))	125 Hz	250 Hz	500 Hz	1000 Hz	2000 Hz	4000 Hz	8000 Hz	Overall Lw (dB(A))	125 Hz	250 Hz	500 Hz	1000 Hz	2000 Hz	4000 Hz	8000 Hz	Overall Lw (dB(A))
300	38	33	29	25	22	12	12	33	44	38	40	40	31	22	15	42	43	44	42	38	37	29	22	44	43	49	44	36	41	36	30	47
350	38	33	30	27	22	13	12	33	46	40	41	41	33	24	17	44	46	46	44	41	38	31	24	46	46	51	46	40	43	38	32	49
400	38	34	31	30	23	13	13	34	47	42	42	43	34	26	18	46	49	47	45	44	40	33	26	48	50	52	48	44	45	40	33	52
450	37	34	33	33	23	14	13	36	49	44	43	45	36	28	20	47	51	49	47	47	42	35	28	50	54	54	51	49	47	42	35	54
500	37	34	34	36	24	15	14	38	50	46	45	47	37	29	22	49	54	51	49	50	43	37	30	53	58	55	53	53	49	44	37	57
550	38	36	37	38	26	18	15	40	50	46	45	47	38	31	23	49	53	51	49	50	44	38	31	53	57	55	53	54	50	44	37	57
650	40	39	41	42	31	23	18	44	49	46	46	46	40	33	25	50	52	50	50	51	45	39	32	54	55	54	54	55	51	45	38	58