

TECHNICAL CATALOGUE

We care about healthy air

**Floor convectors
TK-13 with natural
convection**

Floor convector with natural convection TK-13



TK-13 floor convectors with natural convection

Natural convection floor convectors are designed for secondary room heating with heating capacities up to 5 kW. They are distinguished for their silent operation and thus especially suitable for residential premises.

Application

Natural convection floor convectors are applied as secondary heating bodies, in combination with other primary heating bodies (e.g. TKV floor convectors with forced convection, fan coils or s dows, doors and other cold surfaces. Recommended distance between floor convector and glass surface is 50-200 mm.

Floor convectors are used for partial covering of heat losses, prevention of condensation on glass surfaces, reduction of the convection effect from cold surfaces and prevention of cold outside air intrusion.

Components

Basic design:

1. Heat exchanger
2. Tread-on grille
3. Housing

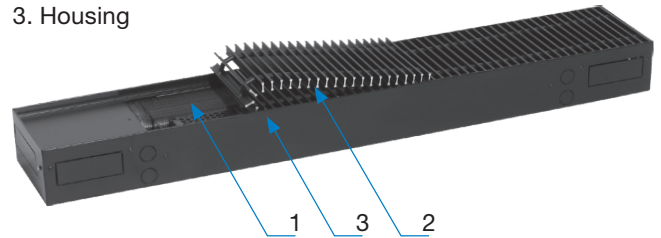

Dimensions

- Standard widths: 200, 300, 400 mm
- Standard heights: 70, 80, 105, 140 mm
- Narrow version: width 150 mm, height 110 mm
- Available in 33 lengths from 800 - 5000 mm
- In the range up to 3000 mm lengths are available in the increments of 100 mm, while lengths over 3000 mm are available in the increments of 200 mm.

Accessories

The basic version has no water side control components. They have to be ordered as accessories (e.g. valves 01,...,VP2).

Selection

User friendly selection software makes it easy to select the optimum floor convector for individual projects.

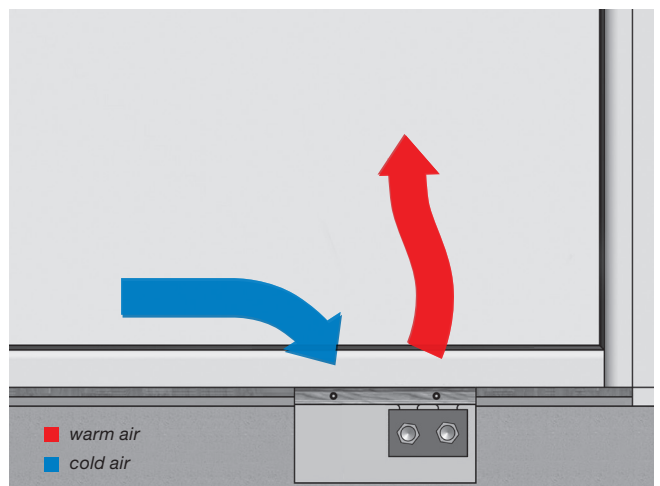
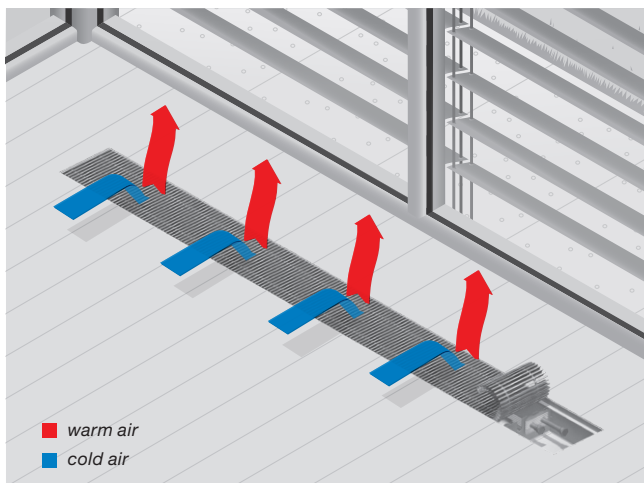

Technical data

TK-13 Lx20x07

Housing length L [mm]	Heating capacity								
	75 °C / 65 °C / 20 °C			90 °C / 70 °C / 20 °C			55 °C / 45 °C / 20 °C		
	Q_h	\dot{m}_w	Δp_w	Q_h	\dot{m}_w	Δp_w	Q_h	\dot{m}_w	Δp_w
	[W]	[kg/h]	[kPa]	[W]	[kg/h]	[kPa]	[W]	[kg/h]	[kPa]
800	131	11.3	<0.01	164	7.1	<0.01	61	5.2	<0.01
900	157	13.5	<0.01	197	8.5	<0.01	73	6.3	<0.01
1000	184	15.8	<0.01	230	9.9	<0.01	85	7.3	<0.01
1100	210	18.0	<0.01	263	11.3	<0.01	97	8.3	<0.01
1200	236	20.3	<0.01	296	12.7	<0.01	109	9.4	<0.01
1300	262	22.5	0.01	329	14.1	<0.01	121	10.4	<0.01
1400	289	24.8	0.01	362	15.5	<0.01	133	11.5	<0.01
1500	315	27.0	0.01	395	17.0	<0.01	146	12.5	<0.01
1600	341	29.3	0.01	428	18.4	<0.01	158	13.5	<0.01
1700	367	31.6	0.01	460	19.8	0.01	170	14.6	<0.01
1800	394	33.8	0.02	493	21.2	0.01	182	15.6	<0.01
1900	420	36.1	0.02	526	22.6	0.01	194	16.7	<0.01
2000	446	38.3	0.02	559	24.0	0.01	206	17.7	0.01
2100	472	40.6	0.03	592	25.4	0.01	218	18.8	0.01
2200	498	42.8	0.03	625	26.8	0.01	230	19.8	0.01
2300	525	45.1	0.04	658	28.3	0.02	243	20.8	0.01
2400	551	47.3	0.05	691	29.7	0.02	255	21.9	0.01
2500	577	49.6	0.05	724	31.1	0.02	267	22.9	0.01
2600	603	51.8	0.06	756	32.5	0.02	279	24.0	0.01
2700	630	54.1	0.07	789	33.9	0.03	291	25.0	0.01
2800	656	56.4	0.08	822	35.3	0.03	303	26.0	0.02
2900	682	58.6	0.09	855	36.7	0.03	315	27.1	0.02
3000	708	60.9	0.10	888	38.2	0.04	327	28.1	0.02
3200	761	65.4	0.12	954	41.0	0.05	352	30.2	0.03
3400	813	69.9	0.14	1020	43.8	0.06	376	32.3	0.03
3600	866	74.4	0.17	1085	46.6	0.07	400	34.4	0.04
3800	918	78.9	0.21	1151	49.5	0.08	424	36.5	0.04
4000	971	83.4	0.24	1217	52.3	0.10	449	38.6	0.05
4200	1023	87.9	0.29	1283	55.1	0.11	473	40.6	0.06
4400	1076	92.4	0.33	1349	57.9	0.13	497	42.7	0.07
4600	1128	96.9	0.38	1414	60.8	0.15	521	44.8	0.08
4800	1181	101.4	0.44	1480	63.6	0.17	546	46.9	0.09
5000	1233	105.9	0.50	1546	66.4	0.20	570	49.0	0.11

Q_h [W]: Heating capacity \dot{m}_w [kg/h]: Water flow Δp_w [kPa]: Pressure drop on the water side

Technical data

TK-13 Lx30x07

Housing length L [mm]	Heating capacity								
	75 °C / 65 °C / 20 °C			90 °C / 70 °C / 20 °C			55 °C / 45 °C / 20 °C		
	Q_h	\dot{m}_w	Δp_w	Q_h	\dot{m}_w	Δp_w	Q_h	\dot{m}_w	Δp_w
	[W]	[kg/h]	[kPa]	[W]	[kg/h]	[kPa]	[W]	[kg/h]	[kPa]
800	199	17.1	<0.01	250	10.7	<0.01	92	7.9	<0.01
900	239	20.5	0.01	300	12.9	<0.01	110	9.5	<0.01
1000	279	24.0	0.01	349	15.0	<0.01	129	11.1	<0.01
1100	319	27.4	0.01	399	17.2	<0.01	147	12.7	<0.01
1200	358	30.8	0.02	449	19.3	0.01	166	14.2	<0.01
1300	398	34.2	0.02	499	21.4	0.01	184	15.8	<0.01
1400	438	37.6	0.03	549	23.6	0.01	202	17.4	0.01
1500	478	41.1	0.04	599	25.7	0.02	221	19.0	0.01
1600	518	44.5	0.05	649	27.9	0.02	239	20.6	0.01
1700	558	47.9	0.06	699	30.0	0.02	258	22.1	0.01
1800	597	51.3	0.08	749	32.2	0.03	276	23.7	0.02
1900	637	54.7	0.09	799	34.3	0.04	295	25.3	0.02
2000	677	58.2	0.11	849	36.5	0.04	313	26.9	0.02
2100	717	61.6	0.13	899	38.6	0.05	331	28.5	0.03
2200	757	65.0	0.15	949	40.8	0.06	350	30.0	0.03
2300	796	68.4	0.18	999	42.9	0.07	368	31.6	0.04
2400	836	71.9	0.20	1048	45.0	0.08	387	33.2	0.04
2500	876	75.3	0.24	1098	47.2	0.09	405	34.8	0.05
2600	916	78.7	0.27	1148	49.3	0.11	423	36.4	0.06
2700	956	82.1	0.30	1198	51.5	0.12	442	38.0	0.07
2800	996	85.5	0.34	1248	53.6	0.14	460	39.5	0.07
2900	1035	89.0	0.39	1298	55.8	0.15	479	41.1	0.08
3000	1075	92.4	0.43	1348	57.9	0.17	497	42.7	0.09
3200	1155	99.2	0.54	1448	62.2	0.21	534	45.9	0.11
3400	1235	106.1	0.65	1548	66.5	0.26	571	49.0	0.14
3600	1314	112.9	0.79	1648	70.8	0.31	607	52.2	0.17
3800	1394	119.8	0.94	1747	75.1	0.37	644	55.4	0.20
4000	1473	126.6	1.11	1847	79.4	0.44	681	58.5	0.24
4200	1553	133.4	1.30	1947	83.6	0.51	718	61.7	0.28
4400	1633	140.3	1.51	2047	87.9	0.59	755	64.8	0.32
4600	1712	147.1	1.74	2147	92.2	0.68	792	68.0	0.37
4800	1792	154.0	1.99	2247	96.5	0.78	828	71.2	0.43
5000	1872	160.8	2.27	2347	100.8	0.89	865	74.3	0.49

Q_h [W]: Heating capacity \dot{m}_w [kg/h]: Water flow Δp_w [kPa]: Pressure drop on the water side

Technical data

TK-13 Lx40x07

Housing length L [mm]	Heating capacity								
	75 °C / 65 °C / 20 °C			90 °C / 70 °C / 20 °C			55 °C / 45 °C / 20 °C		
	Q_h	\dot{m}_w	Δp_w	Q_h	\dot{m}_w	Δp_w	Q_h	\dot{m}_w	Δp_w
	[W]	[kg/h]	[kPa]	[W]	[kg/h]	[kPa]	[W]	[kg/h]	[kPa]
800	284	24.4	0.01	355	15.3	<0.01	131	11.3	<0.01
900	340	29.2	0.01	427	18.3	0.01	157	13.5	<0.01
1000	397	34.1	0.02	498	21.4	0.01	183	15.8	0.01
1100	454	39.0	0.03	569	24.4	0.01	210	18.0	0.01
1200	510	43.8	0.05	640	27.5	0.02	236	20.3	0.01
1300	567	48.7	0.07	711	30.5	0.03	262	22.5	0.01
1400	624	53.6	0.09	782	33.6	0.04	288	24.8	0.02
1500	680	58.5	0.12	853	36.6	0.05	315	27.0	0.02
1600	737	63.3	0.15	924	39.7	0.06	341	29.3	0.03
1700	794	68.2	0.18	995	42.8	0.07	367	31.5	0.04
1800	851	73.1	0.23	1066	45.8	0.09	393	33.8	0.05
1900	907	78.0	0.27	1137	48.9	0.11	419	36.0	0.06
2000	964	82.8	0.33	1209	51.9	0.13	446	38.3	0.07
2100	1021	87.7	0.39	1280	55.0	0.15	472	40.5	0.08
2200	1077	92.6	0.46	1351	58.0	0.18	498	42.8	0.10
2300	1134	97.4	0.53	1422	61.1	0.21	524	45.0	0.11
2400	1191	102.3	0.62	1493	64.1	0.24	550	47.3	0.13
2500	1248	107.2	0.71	1564	67.2	0.28	577	49.5	0.15
2600	1304	112.1	0.81	1635	70.2	0.32	603	51.8	0.17
2700	1361	116.9	0.92	1706	73.3	0.36	629	54.0	0.20
2800	1418	121.8	1.04	1777	76.4	0.41	655	56.3	0.22
2900	1474	126.7	1.17	1848	79.4	0.46	681	58.6	0.25
3000	1531	131.5	1.31	1919	82.5	0.52	708	60.8	0.28
3200	1644	141.3	1.62	2062	88.6	0.64	760	65.3	0.35
3400	1758	151.0	1.98	2204	94.7	0.78	813	69.8	0.42
3600	1871	160.8	2.39	2346	100.8	0.94	865	74.3	0.51
3800	1985	170.5	2.85	2488	106.9	1.12	917	78.8	0.61
4000	2098	180.3	3.36	2630	113.0	1.32	970	83.3	0.72
4200	2212	190.0	3.94	2773	119.1	1.55	1022	87.8	0.84
4400	2325	199.8	4.58	2915	125.2	1.80	1075	92.3	0.98
4600	2438	209.5	5.28	3057	131.3	2.07	1127	96.8	1.13
4800	2552	219.2	6.05	3199	137.4	2.38	1180	101.3	1.29
5000	2665	229.0	6.89	3341	143.5	2.71	1232	105.8	1.47

Q_h [W]: Heating capacity \dot{m}_w [kg/h]: Water flow Δp_w [kPa]: Pressure drop on the water side

Technical data

TK-13 Lx20x08

Housing length L [mm]	Heating capacity								
	75 °C / 65 °C / 20 °C			90 °C / 70 °C / 20 °C			55 °C / 45 °C / 20 °C		
	Q_h	\dot{m}_w	Δp_w	Q_h	\dot{m}_w	Δp_w	Q_h	\dot{m}_w	Δp_w
	[W]	[kg/h]	[kPa]	[W]	[kg/h]	[kPa]	[W]	[kg/h]	[kPa]
800	118	10.2	<0.01	148	6.4	<0.01	55	4.7	<0.01
900	142	12.2	<0.01	178	7.6	<0.01	66	5.6	<0.01
1000	166	14.2	<0.01	208	8.9	<0.01	77	6.6	<0.01
1100	189	16.3	<0.01	237	10.2	<0.01	87	7.5	<0.01
1200	213	18.3	<0.01	267	11.5	<0.01	98	8.5	<0.01
1300	236	20.3	<0.01	296	12.7	<0.01	109	9.4	<0.01
1400	260	22.3	0.01	326	14.0	<0.01	120	10.3	<0.01
1500	284	24.4	0.01	356	15.3	<0.01	131	11.3	<0.01
1600	307	26.4	0.01	385	16.6	<0.01	142	12.2	<0.01
1700	331	28.4	0.01	415	17.8	<0.01	153	13.1	<0.01
1800	355	30.5	0.01	445	19.1	0.01	164	14.1	<0.01
1900	378	32.5	0.02	474	20.4	0.01	175	15.0	<0.01
2000	402	34.5	0.02	504	21.7	0.01	186	16.0	<0.01
2100	426	36.6	0.02	534	22.9	0.01	197	16.9	<0.01
2200	449	38.6	0.03	563	24.2	0.01	208	17.8	0.01
2300	473	40.6	0.03	593	25.5	0.01	219	18.8	0.01
2400	497	42.7	0.04	623	26.7	0.01	230	19.7	0.01
2500	520	44.7	0.04	652	28.0	0.02	240	20.7	0.01
2600	544	46.7	0.05	682	29.3	0.02	251	21.6	0.01
2700	568	48.8	0.05	711	30.6	0.02	262	22.5	0.01
2800	591	50.8	0.06	741	31.8	0.02	273	23.5	0.01
2900	615	52.8	0.07	771	33.1	0.03	284	24.4	0.01
3000	638	54.9	0.08	800	34.4	0.03	295	25.4	0.02
3200	686	58.9	0.10	860	36.9	0.04	317	27.2	0.02
3400	733	63.0	0.12	919	39.5	0.05	339	29.1	0.02
3600	780	67.0	0.14	978	42.0	0.06	361	31.0	0.03
3800	828	71.1	0.17	1038	44.6	0.07	383	32.9	0.04
4000	875	75.2	0.20	1097	47.1	0.08	404	34.7	0.04
4200	922	79.2	0.23	1156	49.7	0.09	426	36.6	0.05
4400	970	83.3	0.27	1215	52.2	0.11	448	38.5	0.06
4600	1017	87.4	0.31	1275	54.8	0.12	470	40.4	0.07
4800	1064	91.4	0.35	1334	57.3	0.14	492	42.3	0.08
5000	1111	95.5	0.40	1393	59.9	0.16	514	44.1	0.09

Q_h [W]: Heating capacity \dot{m}_w [kg/h]: Water flow Δp_w [kPa]: Pressure drop on the water side

Technical data

TK-13 Lx30x08

Housing length L [mm]	Heating capacity								
	75 °C / 65 °C / 20 °C			90 °C / 70 °C / 20 °C			55 °C / 45 °C / 20 °C		
	Q_h	\dot{m}_w	Δp_w	Q_h	\dot{m}_w	Δp_w	Q_h	\dot{m}_w	Δp_w
	[W]	[kg/h]	[kPa]	[W]	[kg/h]	[kPa]	[W]	[kg/h]	[kPa]
800	171	14.7	<0.01	202	8.7	<0.01	94	8.1	<0.01
900	206	17.7	<0.01	243	10.4	<0.01	113	9.7	<0.01
1000	240	20.6	0.01	283	12.2	<0.01	132	11.3	<0.01
1100	274	23.6	0.01	323	13.9	<0.01	150	12.9	<0.01
1200	309	26.5	0.01	364	15.6	<0.01	169	14.5	<0.01
1300	343	29.5	0.02	404	17.4	0.01	188	16.2	0.01
1400	377	32.4	0.02	445	19.1	0.01	207	17.8	0.01
1500	412	35.4	0.03	485	20.8	0.01	226	19.4	0.01
1600	446	38.3	0.04	526	22.6	0.01	245	21.0	0.01
1700	480	41.3	0.05	566	24.3	0.02	263	22.6	0.01
1800	514	44.2	0.06	606	26.1	0.02	282	24.2	0.02
1900	549	47.1	0.07	647	27.8	0.02	301	25.9	0.02
2000	583	50.1	0.08	687	29.5	0.03	320	27.5	0.02
2100	617	53.0	0.10	728	31.3	0.03	339	29.1	0.03
2200	652	56.0	0.11	768	33.0	0.04	357	30.7	0.03
2300	686	58.9	0.13	809	34.7	0.05	376	32.3	0.04
2400	720	61.9	0.15	849	36.5	0.05	395	33.9	0.05
2500	754	64.8	0.17	889	38.2	0.06	414	35.6	0.05
2600	789	67.8	0.20	930	39.9	0.07	433	37.2	0.06
2700	823	70.7	0.23	970	41.7	0.08	451	38.8	0.07
2800	857	73.7	0.26	1011	43.4	0.09	470	40.4	0.08
2900	892	76.6	0.29	1051	45.2	0.10	489	42.0	0.09
3000	926	79.6	0.32	1092	46.9	0.11	508	43.6	0.10
3200	995	85.4	0.40	1172	50.4	0.14	545	46.9	0.12
3400	1063	91.3	0.49	1253	53.8	0.17	583	50.1	0.15
3600	1132	97.2	0.59	1334	57.3	0.20	621	53.3	0.18
3800	1200	103.1	0.70	1415	60.8	0.24	658	56.6	0.21
4000	1269	109.0	0.82	1496	64.3	0.29	696	59.8	0.25
4200	1337	114.9	0.96	1577	67.7	0.33	734	63.0	0.29
4400	1406	120.8	1.12	1658	71.2	0.39	771	66.3	0.34
4600	1475	126.7	1.29	1738	74.7	0.45	809	69.5	0.39
4800	1543	132.6	1.48	1819	78.2	0.51	846	72.7	0.44
5000	1612	138.5	1.68	1900	81.6	0.59	884	76.0	0.51

Q_h [W]: Heating capacity \dot{m}_w [kg/h]: Water flow Δp_w [kPa]: Pressure drop on the water side

Technical data

TK-13 Lx20x10

Housing length L [mm]	Heating capacity								
	75 °C / 65 °C / 20 °C			90 °C / 70 °C / 20 °C			55 °C / 45 °C / 20 °C		
	Q_h	\dot{m}_w	Δp_w	Q_h	\dot{m}_w	Δp_w	Q_h	\dot{m}_w	Δp_w
	[W]	[kg/h]	[kPa]	[W]	[kg/h]	[kPa]	[W]	[kg/h]	[kPa]
800	161	13.8	<0.01	202	8.7	<0.01	74	6.4	<0.01
900	193	16.6	<0.01	243	10.4	<0.01	89	7.7	<0.01
1000	226	19.4	<0.01	283	12.2	<0.01	104	9.0	<0.01
1100	258	22.2	<0.01	323	13.9	<0.01	119	10.2	<0.01
1200	290	24.9	0.01	364	15.6	<0.01	134	11.5	<0.01
1300	322	27.7	0.01	404	17.4	<0.01	149	12.8	<0.01
1400	355	30.5	0.01	445	19.1	<0.01	164	14.1	<0.01
1500	387	33.2	0.01	485	20.8	0.01	179	15.3	<0.01
1600	419	36.0	0.02	526	22.6	0.01	194	16.6	<0.01
1700	451	38.8	0.02	566	24.3	0.01	208	17.9	<0.01
1800	484	41.5	0.03	606	26.1	0.01	223	19.2	0.01
1900	516	44.3	0.03	647	27.8	0.01	238	20.5	0.01
2000	548	47.1	0.04	687	29.5	0.01	253	21.7	0.01
2100	580	49.9	0.04	728	31.3	0.02	268	23.0	0.01
2200	612	52.6	0.05	768	33.0	0.02	283	24.3	0.01
2300	645	55.4	0.06	809	34.7	0.02	298	25.6	0.01
2400	677	58.2	0.07	849	36.5	0.03	313	26.9	0.01
2500	709	60.9	0.08	889	38.2	0.03	328	28.1	0.02
2600	741	63.7	0.09	930	39.9	0.04	342	29.4	0.02
2700	774	66.5	0.10	970	41.7	0.04	357	30.7	0.02
2800	806	69.2	0.11	1011	43.4	0.05	372	32.0	0.02
2900	838	72.0	0.13	1051	45.2	0.05	387	33.3	0.03
3000	870	74.8	0.14	1091	46.9	0.06	402	34.5	0.03
3200	935	80.3	0.18	1172	50.4	0.07	432	37.1	0.04
3400	999	85.9	0.22	1253	53.8	0.09	461	39.7	0.05
3600	1064	91.4	0.26	1334	57.3	0.10	491	42.2	0.06
3800	1128	96.9	0.31	1415	60.8	0.12	521	44.8	0.07
4000	1193	102.5	0.37	1496	64.3	0.14	551	47.3	0.08
4200	1257	108.0	0.43	1577	67.7	0.17	581	49.9	0.09
4400	1322	113.6	0.50	1657	71.2	0.20	610	52.4	0.11
4600	1386	119.1	0.58	1738	74.7	0.23	640	55.0	0.12
4800	1451	124.6	0.66	1819	78.2	0.26	670	57.6	0.14
5000	1515	130.2	0.75	1900	81.6	0.30	700	60.1	0.16

Q_h [W]: Heating capacity \dot{m}_w [kg/h]: Water flow Δp_w [kPa]: Pressure drop on the water side

Technical data

TK-13 Lx30x10

Housing length L [mm]	Heating capacity								
	75 °C / 65 °C / 20 °C			90 °C / 70 °C / 20 °C			55 °C / 45 °C / 20 °C		
	Q_h	\dot{m}_w	Δp_w	Q_h	\dot{m}_w	Δp_w	Q_h	\dot{m}_w	Δp_w
	[W]	[kg/h]	[kPa]	[W]	[kg/h]	[kPa]	[W]	[kg/h]	[kPa]
800	254	21.8	<0.01	311	13.4	<0.01	126	10.8	<0.01
900	305	26.2	0.01	373	16.0	<0.01	151	13.0	<0.01
1000	356	30.6	0.01	435	18.7	<0.01	176	15.1	<0.01
1100	407	34.9	0.02	498	21.4	0.01	201	17.3	<0.01
1200	457	39.3	0.03	560	24.0	0.01	226	19.4	0.01
1300	508	43.7	0.04	622	26.7	0.01	251	21.6	0.01
1400	559	48.0	0.05	684	29.4	0.02	276	23.7	0.01
1500	610	52.4	0.06	746	32.1	0.02	301	25.9	0.02
1600	661	56.8	0.08	809	34.7	0.03	327	28.1	0.02
1700	712	61.1	0.10	871	37.4	0.04	352	30.2	0.02
1800	762	65.5	0.12	933	40.1	0.05	377	32.4	0.03
1900	813	69.9	0.15	995	42.7	0.06	402	34.5	0.04
2000	864	74.2	0.18	1057	45.4	0.07	427	36.7	0.04
2100	915	78.6	0.21	1119	48.1	0.08	452	38.9	0.05
2200	966	83.0	0.25	1182	50.8	0.09	477	41.0	0.06
2300	1016	87.3	0.29	1244	53.4	0.11	502	43.2	0.07
2400	1067	91.7	0.33	1306	56.1	0.12	528	45.3	0.08
2500	1118	96.1	0.38	1368	58.8	0.14	553	47.5	0.09
2600	1169	100.4	0.44	1430	61.5	0.16	578	49.6	0.11
2700	1220	104.8	0.50	1493	64.1	0.19	603	51.8	0.12
2800	1271	109.2	0.56	1555	66.8	0.21	628	54.0	0.14
2900	1321	113.5	0.63	1617	69.5	0.24	653	56.1	0.15
3000	1372	117.9	0.71	1679	72.1	0.26	678	58.3	0.17
3200	1474	126.6	0.87	1804	77.5	0.33	729	62.6	0.21
3400	1576	135.4	1.07	1928	82.8	0.40	779	66.9	0.26
3600	1677	144.1	1.29	2052	88.2	0.48	829	71.2	0.31
3800	1779	152.8	1.53	2177	93.5	0.57	879	75.6	0.37
4000	1880	161.6	1.81	2301	98.9	0.68	930	79.9	0.44
4200	1982	170.3	2.12	2426	104.2	0.79	980	84.2	0.52
4400	2084	179.0	2.46	2550	109.5	0.92	1030	88.5	0.60
4600	2185	187.8	2.83	2674	114.9	1.06	1080	92.8	0.69
4800	2287	196.5	3.25	2799	120.2	1.22	1131	97.1	0.79
5000	2389	205.2	3.70	2923	125.6	1.38	1181	101.5	0.90

Q_h [W]: Heating capacity \dot{m}_w [kg/h]: Water flow Δp_w [kPa]: Pressure drop on the water side

Technical data

TK-13 Lx40x10

Housing length L [mm]	Heating capacity								
	75 °C / 65 °C / 20 °C			90 °C / 70 °C / 20 °C			55 °C / 45 °C / 20 °C		
	Q_h	\dot{m}_w	Δp_w	Q_h	\dot{m}_w	Δp_w	Q_h	\dot{m}_w	Δp_w
	[W]	[kg/h]	[kPa]	[W]	[kg/h]	[kPa]	[W]	[kg/h]	[kPa]
800	340	29.2	0.01	413	17.7	<0.01	173	14.8	<0.01
900	408	35.1	0.02	495	21.3	0.01	207	17.8	0.01
1000	476	40.9	0.03	578	24.8	0.01	242	20.8	0.01
1100	544	46.8	0.05	660	28.4	0.02	276	23.7	0.01
1200	613	52.6	0.07	743	31.9	0.03	311	26.7	0.02
1300	681	58.5	0.10	825	35.5	0.04	345	29.7	0.03
1400	749	64.3	0.13	908	39.0	0.05	380	32.6	0.03
1500	817	70.2	0.17	990	42.5	0.06	414	35.6	0.04
1600	885	76.0	0.21	1073	46.1	0.08	449	38.6	0.05
1700	953	81.9	0.27	1155	49.6	0.10	483	41.5	0.07
1800	1021	87.7	0.33	1238	53.2	0.12	518	44.5	0.08
1900	1089	93.6	0.40	1320	56.7	0.15	552	47.4	0.10
2000	1157	99.4	0.47	1403	60.3	0.17	587	50.4	0.12
2100	1225	105.3	0.56	1485	63.8	0.21	621	53.4	0.14
2200	1293	111.1	0.66	1568	67.4	0.24	656	56.3	0.17
2300	1361	117.0	0.77	1650	70.9	0.28	690	59.3	0.20
2400	1429	122.8	0.89	1733	74.4	0.33	725	62.3	0.23
2500	1497	128.6	1.02	1815	78.0	0.38	759	65.2	0.26
2600	1565	134.5	1.17	1898	81.5	0.43	794	68.2	0.30
2700	1633	140.3	1.33	1980	85.1	0.49	828	71.2	0.34
2800	1701	146.2	1.50	2063	88.6	0.55	863	74.1	0.39
2900	1770	152.0	1.69	2146	92.2	0.62	897	77.1	0.43
3000	1838	157.9	1.89	2228	95.7	0.69	932	80.1	0.49
3200	1974	169.6	2.34	2393	102.8	0.86	1001	86.0	0.60
3400	2110	181.3	2.85	2558	109.9	1.05	1070	91.9	0.73
3600	2246	193.0	3.44	2723	117.0	1.27	1139	97.9	0.89
3800	2382	204.7	4.10	2888	124.1	1.51	1208	103.8	1.06
4000	2518	216.4	4.85	3053	131.2	1.78	1277	109.7	1.25
4200	2654	228.1	5.67	3218	138.3	2.09	1346	115.7	1.46
4400	2790	239.7	6.59	3383	145.3	2.42	1415	121.6	1.70
4600	2927	251.4	7.60	3548	152.4	2.79	1484	127.5	1.95
4800	3063	263.1	8.71	3713	159.5	3.20	1553	133.5	2.24
5000	3199	274.8	9.92	3878	166.6	3.65	1622	139.4	2.55

Q_h [W]: Heating capacity \dot{m}_w [kg/h]: Water flow Δp_w [kPa]: Pressure drop on the water side

Technical data

TK-13 Lx15x11

Housing length L [mm]	Heating capacity								
	75 °C / 65 °C / 20 °C			90 °C / 70 °C / 20 °C			55 °C / 45 °C / 20 °C		
	Q_h	\dot{m}_w	Δp_w	Q_h	\dot{m}_w	Δp_w	Q_h	\dot{m}_w	Δp_w
	[W]	[kg/h]	[kPa]	[W]	[kg/h]	[kPa]	[W]	[kg/h]	[kPa]
800	141	12.2	<0.01	178	7.6	<0.01	65	5.6	<0.01
900	170	14.6	<0.01	213	9.2	<0.01	78	6.7	<0.01
1000	198	17.0	<0.01	249	10.7	<0.01	91	7.8	<0.01
1100	226	19.4	<0.01	284	12.2	<0.01	104	8.9	<0.01
1200	255	21.9	<0.01	320	13.7	<0.01	117	10.1	<0.01
1300	283	24.3	0.01	355	15.3	<0.01	130	11.2	<0.01
1400	311	26.7	0.01	391	16.8	<0.01	143	12.3	<0.01
1500	339	29.2	0.01	426	18.3	<0.01	156	13.4	<0.01
1600	368	31.6	0.01	462	19.8	0.01	169	14.5	<0.01
1700	396	34.0	0.02	498	21.4	0.01	182	15.6	<0.01
1800	424	36.5	0.02	533	22.9	0.01	195	16.8	<0.01
1900	453	38.9	0.02	569	24.4	0.01	208	17.9	<0.01
2000	481	41.3	0.03	604	26.0	0.01	221	19.0	0.01
2100	509	43.7	0.03	640	27.5	0.01	234	20.1	0.01
2200	537	46.2	0.04	675	29.0	0.02	247	21.2	0.01
2300	566	48.6	0.05	711	30.5	0.02	260	22.3	0.01
2400	594	51.0	0.05	746	32.1	0.02	273	23.5	0.01
2500	622	53.5	0.06	782	33.6	0.02	286	24.6	0.01
2600	651	55.9	0.07	817	35.1	0.03	299	25.7	0.01
2700	679	58.3	0.08	853	36.6	0.03	312	26.8	0.02
2800	707	60.8	0.09	888	38.2	0.03	325	27.9	0.02
2900	735	63.2	0.10	924	39.7	0.04	338	29.0	0.02
3000	764	65.6	0.11	959	41.2	0.04	351	30.2	0.02
3200	820	70.5	0.14	1031	44.3	0.05	377	32.4	0.03
3400	877	75.3	0.17	1102	47.3	0.07	403	34.6	0.04
3600	934	80.2	0.20	1173	50.4	0.08	429	36.9	0.04
3800	990	85.1	0.24	1244	53.4	0.09	455	39.1	0.05
4000	1047	89.9	0.28	1315	56.5	0.11	481	41.3	0.06
4200	1103	94.8	0.33	1386	59.5	0.13	507	43.6	0.07
4400	1160	99.7	0.38	1457	62.6	0.15	533	45.8	0.08
4600	1216	104.5	0.44	1528	65.6	0.17	559	48.0	0.09
4800	1273	109.4	0.51	1599	68.7	0.20	585	50.3	0.11
5000	1330	114.2	0.58	1670	71.8	0.23	611	52.5	0.12

Q_h [W]: Heating capacity \dot{m}_w [kg/h]: Water flow Δp_w [kPa]: Pressure drop on the water side

Technical data

TK-13 Lx20x14

Housing length L [mm]	Heating capacity								
	75 °C / 65 °C / 20 °C			90 °C / 70 °C / 20 °C			55 °C / 45 °C / 20 °C		
	Q_h	\dot{m}_w	Δp_w	Q_h	\dot{m}_w	Δp_w	Q_h	\dot{m}_w	Δp_w
	[W]	[kg/h]	[kPa]	[W]	[kg/h]	[kPa]	[W]	[kg/h]	[kPa]
800	211	18.1	<0.01	263	11.3	<0.01	99	8.5	<0.01
900	253	21.7	0.01	316	13.6	<0.01	118	10.2	<0.01
1000	295	25.4	0.01	369	15.8	<0.01	138	11.9	<0.01
1100	337	29.0	0.01	421	18.1	0.01	158	13.5	<0.01
1200	380	32.6	0.02	474	20.4	0.01	177	15.2	<0.01
1300	422	36.2	0.03	527	22.6	0.01	197	16.9	0.01
1400	464	39.9	0.03	579	24.9	0.01	217	18.6	0.01
1500	506	43.5	0.04	632	27.2	0.02	237	20.3	0.01
1600	548	47.1	0.06	685	29.4	0.02	256	22.0	0.01
1700	590	50.7	0.07	737	31.7	0.03	276	23.7	0.02
1800	633	54.4	0.08	790	33.9	0.03	296	25.4	0.02
1900	675	58.0	0.10	843	36.2	0.04	315	27.1	0.02
2000	717	61.6	0.12	895	38.5	0.05	335	28.8	0.03
2100	759	65.2	0.15	948	40.7	0.06	355	30.5	0.03
2200	801	68.9	0.17	1001	43.0	0.07	374	32.2	0.04
2300	844	72.5	0.20	1053	45.3	0.08	394	33.9	0.04
2400	886	76.1	0.23	1106	47.5	0.09	414	35.6	0.05
2500	928	79.7	0.26	1159	49.8	0.10	434	37.3	0.06
2600	970	83.3	0.30	1211	52.0	0.12	453	38.9	0.07
2700	1012	87.0	0.34	1264	54.3	0.13	473	40.6	0.07
2800	1054	90.6	0.39	1317	56.6	0.15	493	42.3	0.08
2900	1097	94.2	0.43	1369	58.8	0.17	512	44.0	0.09
3000	1139	97.8	0.49	1422	61.1	0.19	532	45.7	0.11
3200	1223	105.1	0.60	1527	65.6	0.23	572	49.1	0.13
3400	1307	112.3	0.73	1633	70.1	0.29	611	52.5	0.16
3600	1392	119.6	0.88	1738	74.7	0.34	650	55.9	0.19
3800	1476	126.8	1.06	1843	79.2	0.41	690	59.3	0.23
4000	1561	134.1	1.25	1949	83.7	0.49	729	62.7	0.27
4200	1645	141.3	1.46	2054	88.2	0.57	769	66.0	0.32
4400	1729	148.6	1.69	2159	92.8	0.66	808	69.4	0.37
4600	1814	155.8	1.95	2265	97.3	0.76	848	72.8	0.43
4800	1898	163.1	2.24	2370	101.8	0.87	887	76.2	0.49
5000	1982	170.3	2.55	2475	106.3	0.99	926	79.6	0.56

Q_h [W]: Heating capacity \dot{m}_w [kg/h]: Water flow Δp_w [kPa]: Pressure drop on the water side

Technical data

TK-13 Lx30x14

Housing length L [mm]	Heating capacity								
	75 °C / 65 °C / 20 °C			90 °C / 70 °C / 20 °C			55 °C / 45 °C / 20 °C		
	Q_h	\dot{m}_w	Δp_w	Q_h	\dot{m}_w	Δp_w	Q_h	\dot{m}_w	Δp_w
	[W]	[kg/h]	[kPa]	[W]	[kg/h]	[kPa]	[W]	[kg/h]	[kPa]
800	328	28.2	<0.01	410	17.6	<0.01	153	13.2	<0.01
900	394	33.8	0.01	492	21.1	<0.01	184	15.8	<0.01
1000	460	39.5	0.01	574	24.7	<0.01	215	18.5	<0.01
1100	525	45.1	0.01	656	28.2	0.01	245	21.1	<0.01
1200	591	50.8	0.02	738	31.7	0.01	276	23.7	<0.01
1300	656	56.4	0.03	820	35.2	0.01	307	26.4	0.01
1400	722	62.0	0.03	902	38.7	0.01	337	29.0	0.01
1500	788	67.7	0.04	984	42.3	0.02	368	31.6	0.01
1600	853	73.3	0.06	1066	45.8	0.02	399	34.3	0.01
1700	919	79.0	0.07	1148	49.3	0.03	429	36.9	0.02
1800	985	84.6	0.09	1230	52.8	0.03	460	39.5	0.02
1900	1050	90.2	0.10	1312	56.3	0.04	491	42.2	0.02
2000	1116	95.9	0.12	1394	59.9	0.05	522	44.8	0.03
2100	1182	101.5	0.15	1476	63.4	0.06	552	47.4	0.03
2200	1247	107.2	0.17	1558	66.9	0.07	583	50.1	0.04
2300	1313	112.8	0.20	1640	70.4	0.08	614	52.7	0.04
2400	1379	118.4	0.23	1721	74.0	0.09	644	55.4	0.05
2500	1444	124.1	0.27	1803	77.5	0.10	675	58.0	0.06
2600	1510	129.7	0.31	1885	81.0	0.12	706	60.6	0.07
2700	1576	135.4	0.35	1967	84.5	0.14	736	63.3	0.08
2800	1641	141.0	0.39	2049	88.0	0.15	767	65.9	0.09
2900	1707	146.6	0.44	2131	91.6	0.17	798	68.5	0.10
3000	1772	152.3	0.49	2213	95.1	0.19	828	71.2	0.11
3200	1904	163.6	0.61	2377	102.1	0.24	890	76.4	0.13
3400	2035	174.8	0.74	2541	109.2	0.29	951	81.7	0.16
3600	2166	186.1	0.90	2705	116.2	0.35	1012	87.0	0.20
3800	2298	197.4	1.07	2869	123.3	0.42	1074	92.3	0.23
4000	2429	208.7	1.26	3033	130.3	0.49	1135	97.5	0.28
4200	2560	220.0	1.47	3197	137.3	0.57	1196	102.8	0.32
4400	2692	231.3	1.71	3361	144.4	0.67	1258	108.1	0.37
4600	2823	242.5	1.97	3525	151.4	0.77	1319	113.3	0.43
4800	2954	253.8	2.26	3689	158.5	0.88	1381	118.6	0.49
5000	3085	265.1	2.58	3853	165.5	1.00	1442	123.9	0.56

Q_h [W]: Heating capacity \dot{m}_w [kg/h]: Water flow Δp_w [kPa]: Pressure drop on the water side

Technical data

TK-13 Lx40x14

Housing length L [mm]	Heating capacity								
	75 °C / 65 °C / 20 °C			90 °C / 70 °C / 20 °C			55 °C / 45 °C / 20 °C		
	Q_h	\dot{m}_w	Δp_w	Q_h	\dot{m}_w	Δp_w	Q_h	\dot{m}_w	Δp_w
	[W]	[kg/h]	[kPa]	[W]	[kg/h]	[kPa]	[W]	[kg/h]	[kPa]
800	411	35.3	0.02	513	22.0	0.01	192	16.5	<0.01
900	493	42.3	0.03	615	26.4	0.01	230	19.8	0.01
1000	575	49.4	0.05	718	30.8	0.02	269	23.1	0.01
1100	657	56.4	0.07	820	35.2	0.03	307	26.4	0.02
1200	739	63.5	0.10	923	39.6	0.04	345	29.7	0.02
1300	821	70.6	0.14	1025	44.1	0.06	384	33.0	0.03
1400	903	77.6	0.19	1128	48.5	0.07	422	36.3	0.04
1500	985	84.7	0.24	1231	52.9	0.10	460	39.6	0.05
1600	1068	91.7	0.31	1333	57.3	0.12	499	42.9	0.07
1700	1150	98.8	0.39	1436	61.7	0.15	537	46.2	0.08
1800	1232	105.8	0.48	1538	66.1	0.19	576	49.5	0.10
1900	1314	112.9	0.58	1641	70.5	0.22	614	52.8	0.13
2000	1396	119.9	0.69	1743	74.9	0.27	652	56.1	0.15
2100	1478	127.0	0.82	1846	79.3	0.32	691	59.3	0.18
2200	1560	134.1	0.96	1948	83.7	0.38	729	62.6	0.21
2300	1642	141.1	1.12	2051	88.1	0.44	767	65.9	0.24
2400	1724	148.2	1.30	2153	92.5	0.51	806	69.2	0.28
2500	1807	155.2	1.49	2256	96.9	0.58	844	72.5	0.33
2600	1889	162.3	1.70	2358	101.3	0.66	883	75.8	0.37
2700	1971	169.3	1.93	2461	105.7	0.75	921	79.1	0.42
2800	2053	176.4	2.18	2564	110.1	0.85	959	82.4	0.48
2900	2135	183.4	2.46	2666	114.5	0.96	998	85.7	0.54
3000	2217	190.5	2.75	2769	118.9	1.07	1036	89.0	0.60
3200	2381	204.6	3.40	2974	127.8	1.33	1113	95.6	0.74
3400	2546	218.7	4.16	3179	136.6	1.62	1190	102.2	0.91
3600	2710	232.8	5.01	3384	145.4	1.95	1266	108.8	1.09
3800	2874	246.9	5.98	3589	154.2	2.33	1343	115.4	1.30
4000	3038	261.1	7.06	3794	163.0	2.75	1420	122.0	1.54
4200	3203	275.2	8.26	3999	171.8	3.22	1497	128.6	1.80
4400	3367	289.3	9.59	4204	180.6	3.74	1573	135.2	2.10
4600	3531	303.4	11.06	4409	189.4	4.31	1650	141.8	2.42
4800	3695	317.5	12.68	4614	198.2	4.94	1727	148.4	2.77
5000	3860	331.6	14.44	4820	207.0	5.63	1804	155.0	3.15

Q_h [W]: Heating capacity \dot{m}_w [kg/h]: Water flow Δp_w [kPa]: Pressure drop on the water side

Dimensions

TK-13 Lx20x07

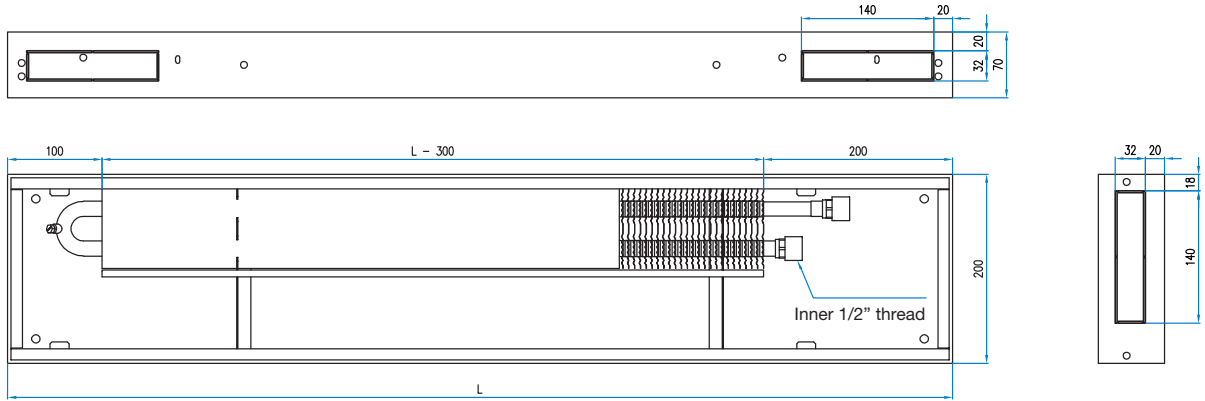

TK-13 Lx30x07

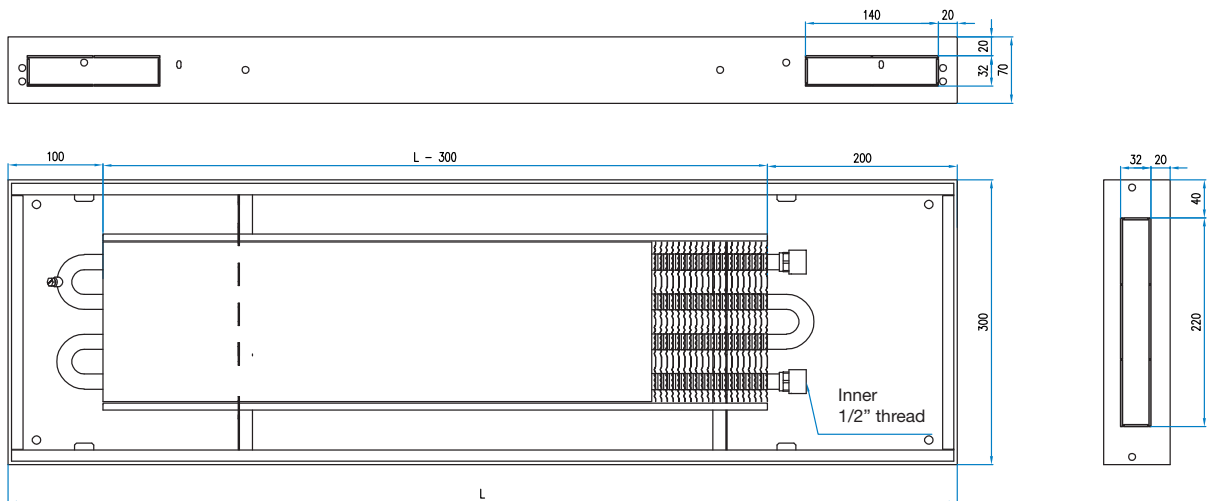

TK-13 Lx40x07

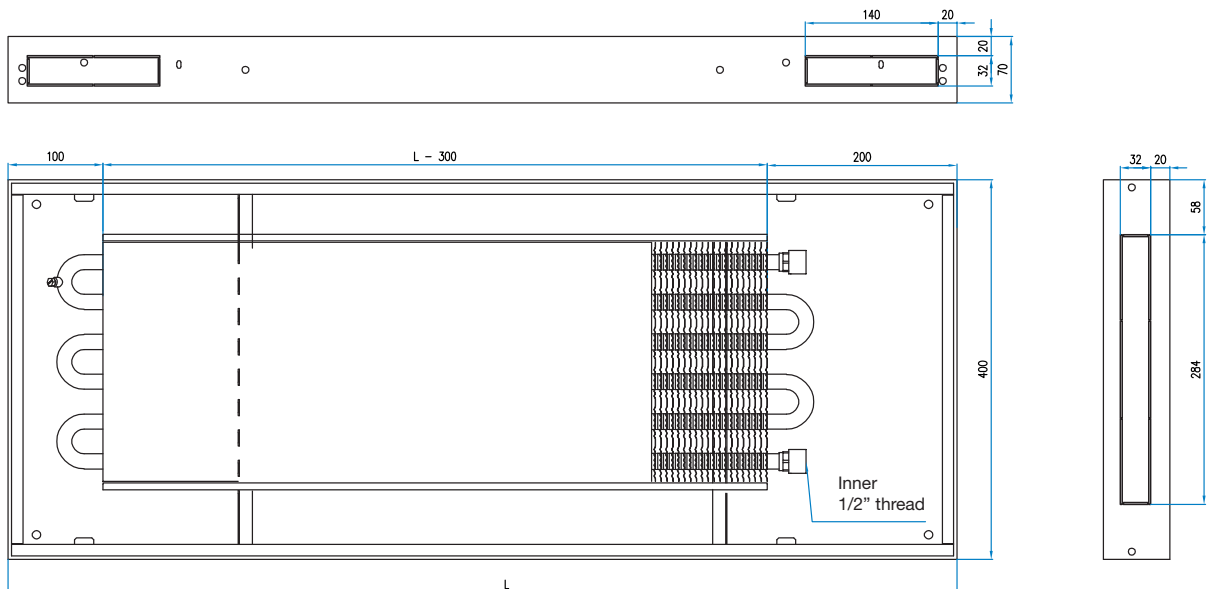

Dimensions

TK-13 Lx30x10

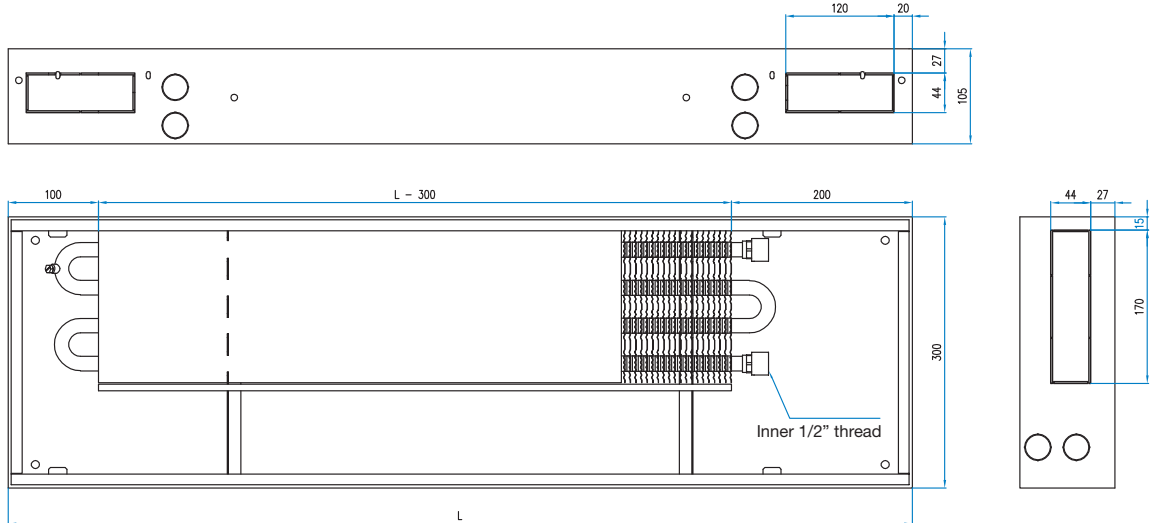

TK-13 Lx40x10

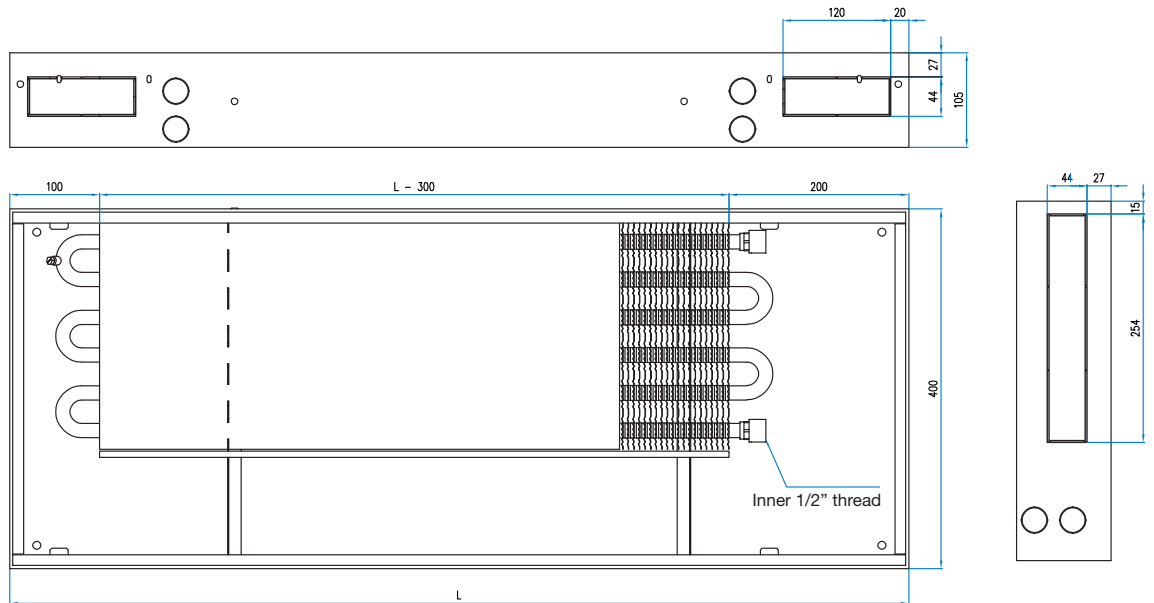

TK-13 Lx15x11

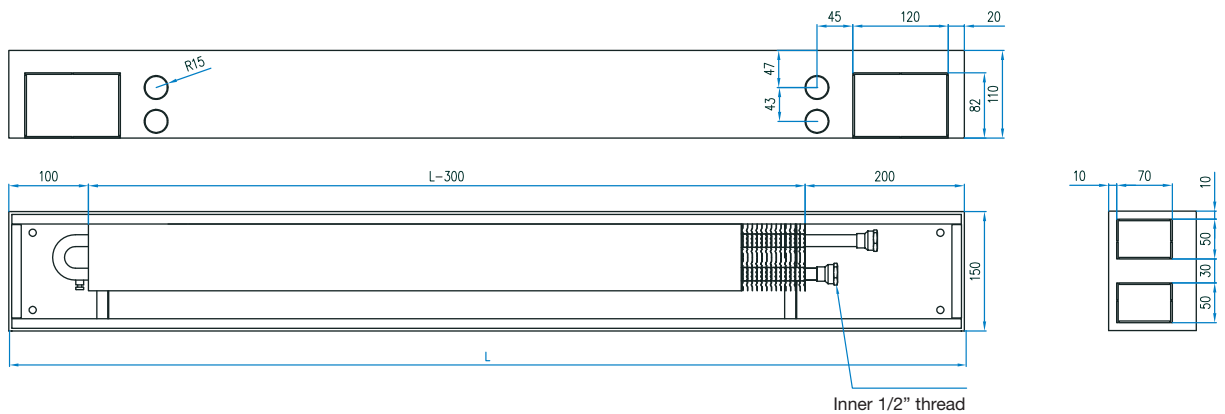

Dimensions

TK-13 Lx20x14

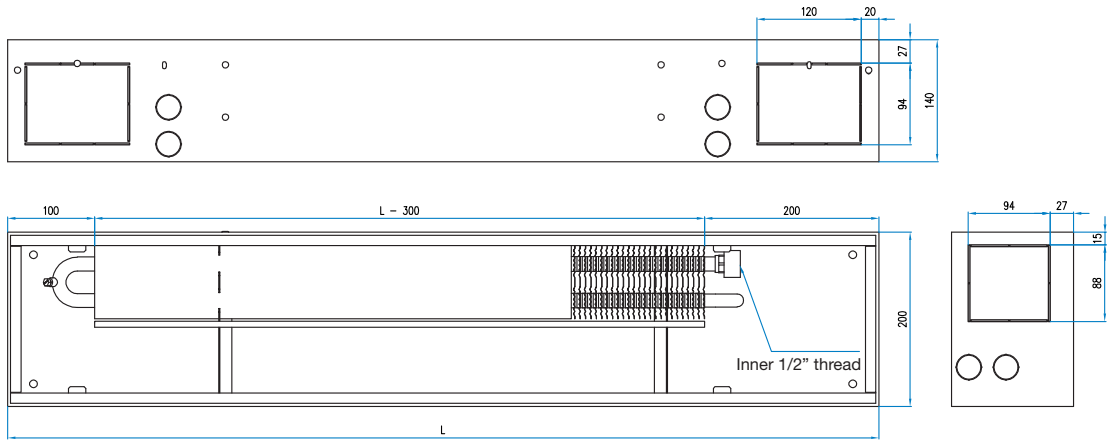

TK-13 Lx30x14

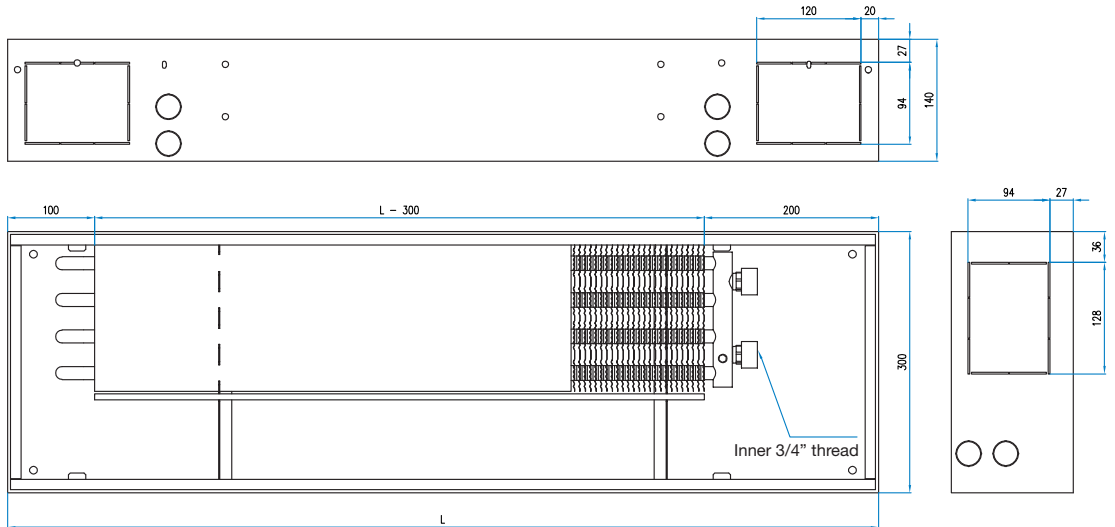

TK-13 Lx40x14

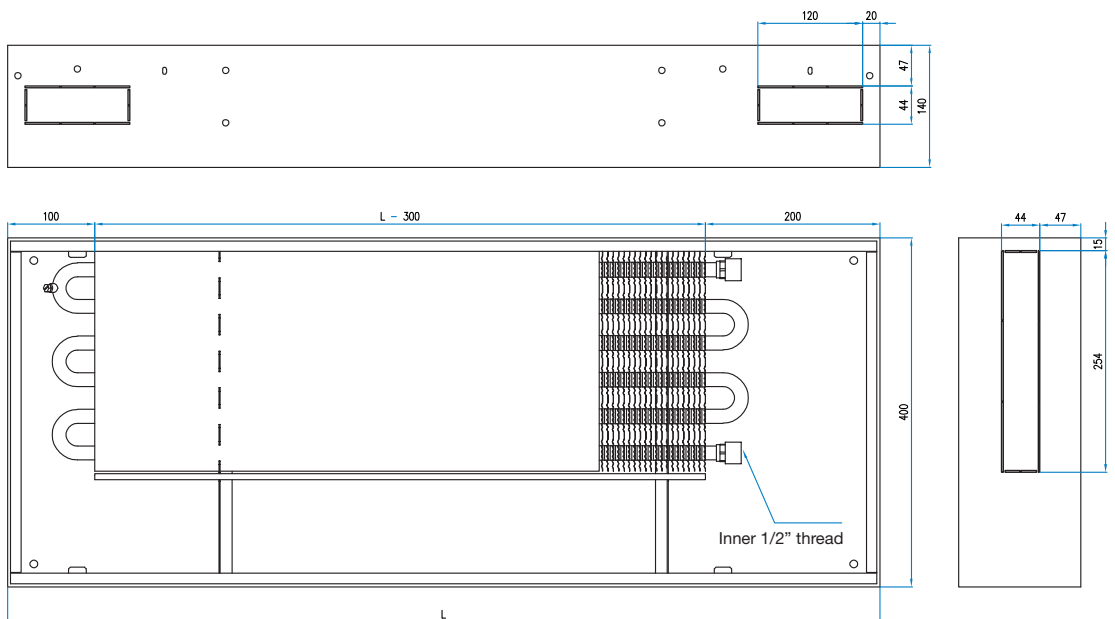

Quick overview of floor convectors TK-13

Basic characteristics

Heating capacities	up to 5 kW
Length	800 – 5000 mm up to 3000 mm increment 100 mm over 3000 mm increment 200 mm
Width	150, 200, 300, 400 mm
Height	70, 80, 105, 110*, 140 mm

*Applies only to models with width 150 mm

Dimensions

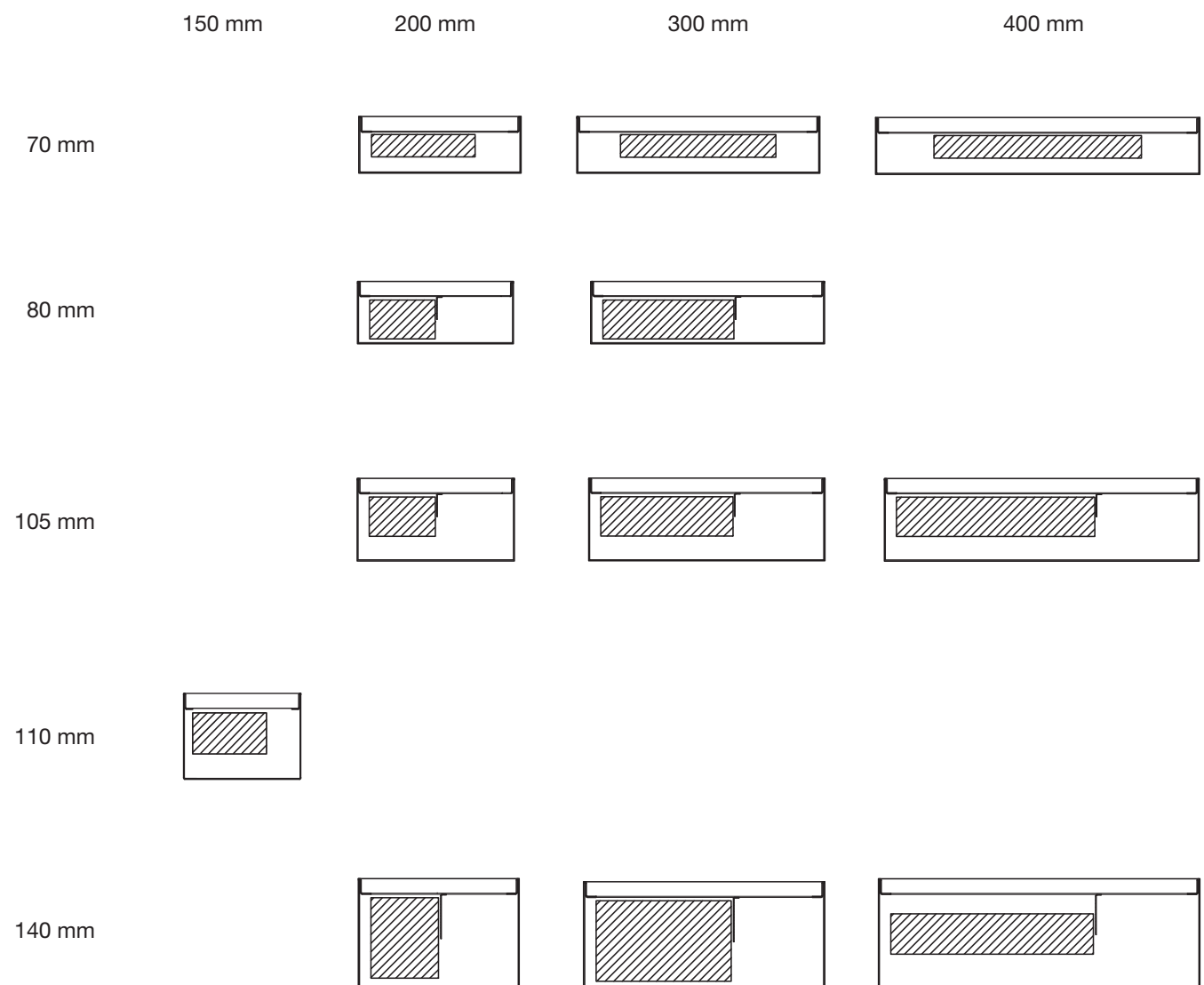

Accessories

Code	Tread-on grille	
111	Standard tread-on grille design: longitudinal fixed aluminium grille	Anodised aluminium natural aluminium colour, black, brass colour, chocolate, bronze*
114	roll-up aluminium grille	Anodised aluminium natural aluminium colour, black, brass colour, chocolate, bronze
114W	roll-up wooden grille	Wood type oak, ash, walnut, mahogany, wenge, cherry
114SS	roll-up steel	Stainless steel

*For longitudinal grilles other grille colors acc. RAL scale are available on customer's request.

Code	Control accessories
	Water side control (control of the warm water flow rate into the convector)
01	Manual valve R1/2", R3/4", straight
02	Manual valve R1/2", R3/4", angular
03	Radiator shut-off cock R1/2", R3/4", straight
04	Radiator shut-off cock R1/2", R3/4", angular
VP2	Two-way valve with ET actuators ON-OFF (2-pipe set)
VT2	Three way valve with ET actuator ON-OFF (2-pipe set)

	Air side control (fan operation control)
T01	Room thermostat for 2-pipe systems, surface installation
T02	LCD room thermostat for 2-pipe systems, semi-flush installation

Code	Other accessories
010(xx°)*	Corner design of convector and grille
017	Housing thermal insulation
018	Wooden protection cover (protection of the convector during the installation)
020(rxxxx)**	Round shaped convector and grille
021	Aluminium frame, fixed to the housing
028	Level adjusting legs, levelling height 20-70 mm
029	Level adjusting and support legs, with reinforced housing (upon request)
032	Connection for fresh air supply, without damper (upon request)
033	Connection for fresh air supply, with damper (upon request)
040	Lowered side

*(xx°) = state desired angle, e.g. 90°

** (rxxxx) = state desired radius on the wall side

Types and colours of tread-on grilles

Longitudinal tread-on grilles are designed to withstand the weight of an individual person, while in case of larger loads roll-up grilles are recommended.

Longitudinal aluminium tread-on grilles

111D longitudinal fixed grille, anodised in natural aluminium colour



111B longitudinal fixed grille, anodised in black colour



111C longitudinal fixed grille, anodised in brass colour



111E longitudinal fixed grille, anodised in chocolate colour



111F longitudinal fixed grille, anodised in bronze colour



Aluminium and stainless steel roll-up grilles

114D roll-up grille, anodised in natural aluminium colour

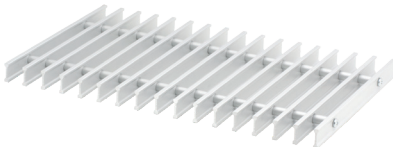

114B roll-up grille, anodised in black colour

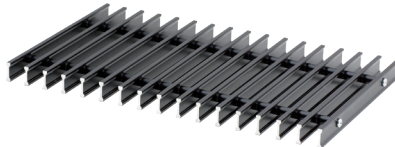

114C roll-up grille, anodised in brass colour

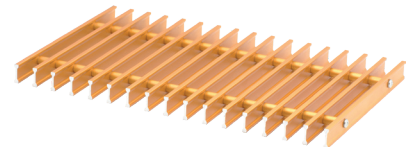

114E roll-up grille, anodised in chocolate colour



114F roll-up grille, anodised in bronze colour

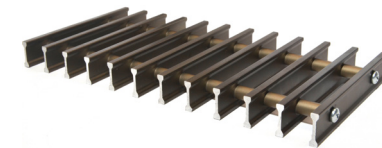

114SS roll-up grille, stainless steel

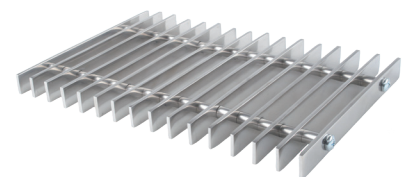

Wooden roll-up grilles

114W1 oak wood

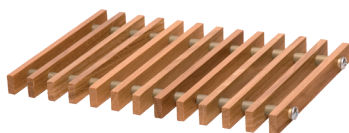

114W2 ash wood

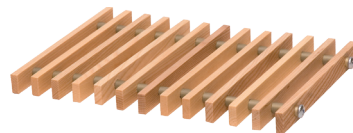

114W3 walnut wood

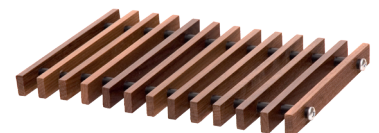

114W4 mahogany wood

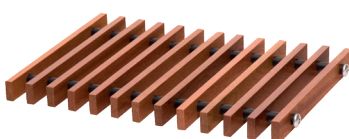

114W5 wenge wood

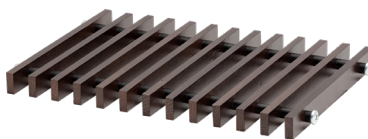

114W6 cherry wood

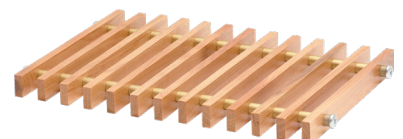

Water side control accessories

01 Manual valve R1/2" ali R3/4", straight

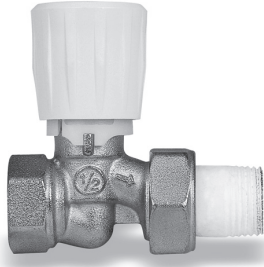

04 Radiator shut-off cock R1/2" or R3/4", angular

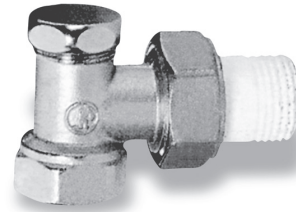

02 Manual valve R1/2" or R3/4", angular

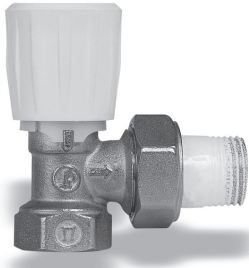

VP2 Two-way valve with ET actuators ON-OFF (2-pipe set)



03 Radiator shut-off cock R1/2" ali R3/4", straight

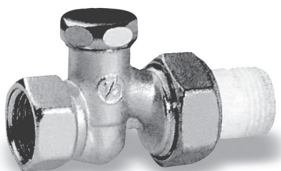

VT2 Three way valve with ET actuator ON-OFF (2-pipe set)



Notes:

- Valve size (R1/2", R3/4") depends on the size of heat exchanger connector size (not necessary to state).
- Manual valves 01-04 are only supplied with the convector but not installed, sets of two- and three-way valves are installed,
- Sets of three-way valves VT2 require more space for installation, possibility of installation should be confirmed by the producer before an order.

Thermostats

T01 Room thermostat

- for 2-pipe systems
- wall installation
- room temperature setup
- manual speed selection
- manual regime (heating – cooling) selection



T02 Electronic LCD room thermostat (touch screen)

- for 2-pipe systems
- semi-flush installation into the enclosed electrical socket
- setup and display of room temperature
- manual or auto speed selection
- manual regime (heating – cooling) selection



Other accessories

010(xx°) Corner design of convector and grille

According to drawing.

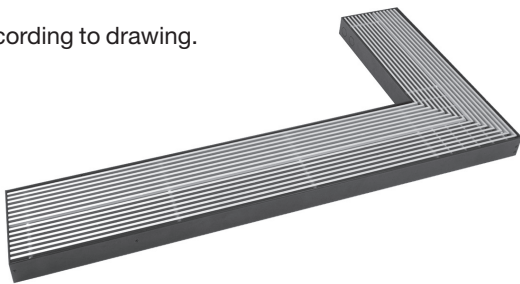

020(rxxxx) Round shaped convector and grille

According to drawing with stated desired radius on the wall side, roll-up grilles only.

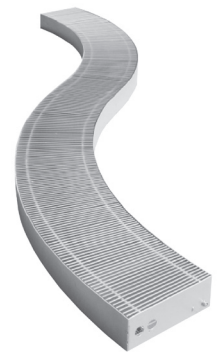

017 Housing thermal insulation



021 Aluminium frame

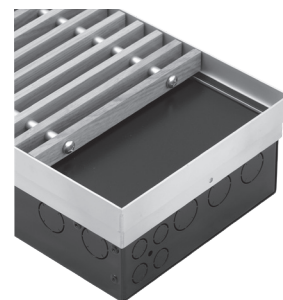

Note:
when ordering accessory 021, length and width of housing increase for 12 mm. The length and width of the grille also change accordingly.

018 Wooden protection cover

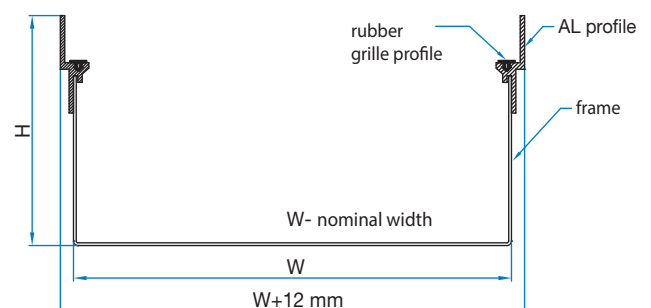
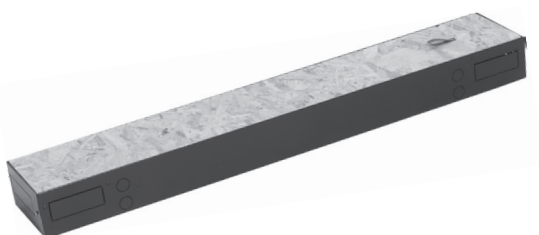



028 Level adjusting legs

- Levelling height (distance to the bottom of floor convector) is 20–70 mm.
- Installation possible in models of 105 and 140 mm height only.
- Different project solutions upon request.



029 Level adjusting and support legs

- Recommended for installation into false floor.
- Set with reinforced housing bracket.
- Available upon request.

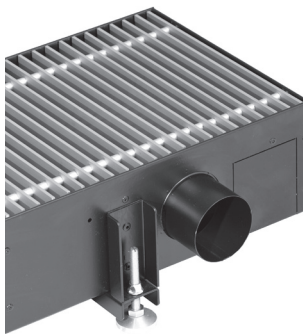

032 Connection for fresh air supply without damper

- The connection for fresh air supply is available as a tailored solution, installation details, connection placement and size are to be clarified with the producer for each project individually

033 Connection for fresh air supply with damper

- The connection for fresh air supply is available as a tailored solution, installation details, connection placement and size are to be clarified with the producer for each project individually.

Example of TK-13 convector with fresh air supply

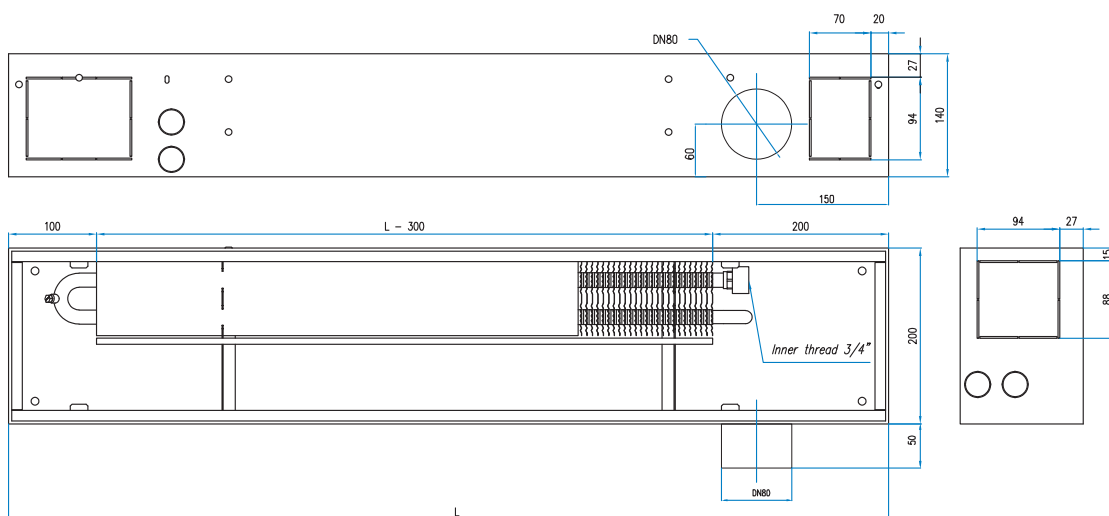

Special versions

Custom-made floor convectors with non-standard dimensions and technical characteristics can be produced on customer's request and according project specifications.

040 Lowered side

- For connecting two or more floor convectors in line. The grille is from one piece limited with maximum grille length.
- Possible lowered side on the right 040R, lowered side on the left 040L, both lowered sides 040R, 040L.

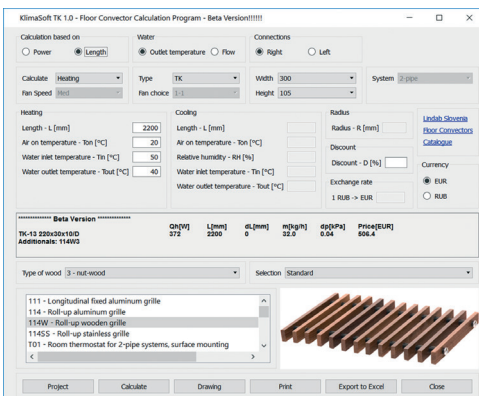

For selection of floor convectors user friendly software is available on request.

Ordering key

TK-13 / 300 X 20 X 10 / R / N / / 01,03 / / 111D / /

1 2a x 2b x 2c 3 4 5 6 7 8 9

1 Type

TK-13 Floor convector with natural convection

2a Length

080-300 800 – 3000 mm (increment 100 mm)

320-500 3200 – 5000 mm (increment 200 mm)

2b Width

15 150 mm (only for H=110 mm)

20 200 mm

30 300 mm

40 400 mm

2c Height

07 70 mm

08 80 mm (only for W= 200, 300)

10 105 mm

11 110 mm (only for W=150 mm)

14 140 mm

3 Water connection side

R Right (convector seen from the room towards the window)

L Left (convector seen from the room towards the window)

4 New floor convector version 2017

N New generation of floor convectors with optimized technical characteristics and price:performance ratio. Recommended option for all TK-13 convectors. Mandatory option, when selecting convectors H=80 mm!

5 Thermostat type

T01 Room thermostat – basic

T02 Room thermostat with touch screen

6 Valve type

01 Manual valve, straight

02 Manual valve, angular

03 Shut-off cock, straight

04 Shut-off cock, angular

VP2 2-way valve with ET actuator

VT2 3-way valve with ET actuator

7 Special housing designs

010(xx°) Corner design (example: angle xx°= 90°)

020(rxxxx) Round shaped housing (example: radius rxxxx = 2000 mm)

8 Grille

111 Longitudinal aluminium grille, anodised

114 Roll-up aluminium grille, anodised

114W Wooden roll-up grille

114SS Stainless steel roll-up grille

9 Accessories

017 Housing thermal insulation

018 Wooden protection cover for increased protection during installation

021 Aluminium decorative frame fixed to the housing

028 Level adjusting legs

029 Level adjusting and support legs, with reinforced housing

032 Fresh air connection without damper

033 Fresh air connection with damper

040R Lowered side on the right

040L Lowered side on the left

Product description, scope of delivery, dimensions

Floor convectors with natural convection TK-13

Housing

- Housing suitable for false floor installation, installation in concrete floors or screed. Operation principle: natural convection.
- The durable, stable box is made of steel sheet powder painted in black color (RAL 9005).
- The adjustable support screws are located inside the housing. Optionally, also support legs mounted outside of the housing are available to increase the housing stability (accessory 029). The support surfaces for the decorative grille in the housing are equipped with a special anti-slip seal that ensures good sound insulation and fit of the grille.
- The connections can be carried out on both side and front housing panel.

Heat exchanger

- The heat exchanger consists of copper pipes and aluminium fins in natural aluminium color and is placed in the housing on steel support brackets.
- Features:
 - End connection;
 - Inner thread 1/2 for models with height 70, 80, 105, 110 and for models with height 140 (width 400 only);
 - Inner thread 3/4 for models with height 140 (widths 200 and 300);
 - Fitted with a de-airing valve;
 - Suitable for operation with a maximum working pressure of 11 bar (maximum allowed pressure 16 bar) and maximum operating temperature 110 °C.

Grille

- As standard, a longitudinal aluminium grille is delivered with the floor convector. The grille is placed on an antivibration sealing tape for improved sound attenuation. The grille itself consist of 18 mm highprofile rods, anodized in natural aluminium color. The effective cross-section is approx. 70 %. Since the grille is made of I-profiles it can be turned over and used equally on both sides.

Standards

- Heating characteristics are measured acc. European standard EN 442.
- Quality management system according to latest standard DIN EN ISO 9001.
- Environmental management system according to latest standard DIN EN ISO 14001.

Dimensions

- Natural convection floor convectors apply the principle of natural circulation of air, caused by temperature differences.
- Cold air enters into the floor convector, is warmed up in the heat exchanger and rises into the room.

Application

- Floor convectors are used as an efficient heating solution for premises with large glazing envelope surfaces such as residential homes, office, public or commercial buildings.

Scope of delivery

- 4 convector widths: 150, 200, 300, 400 mm;
- 5 convector heights: 70, 80, 105, 110, 140 mm;
- 33 convector lengths: from 800 mm to 3000 mm length the increment is 100 mm, from 3000 mm to 5000 mm the increment is 200 mm.

Control accessories

- See description on pages 23-24.



OC IMP Klima d.o.o
Godovič 150
SI - 5275 Godovič

T: +386 5 3743 000
e info@oc-impklima.com