

Rectangular variable air flow regulator ERP-6/7

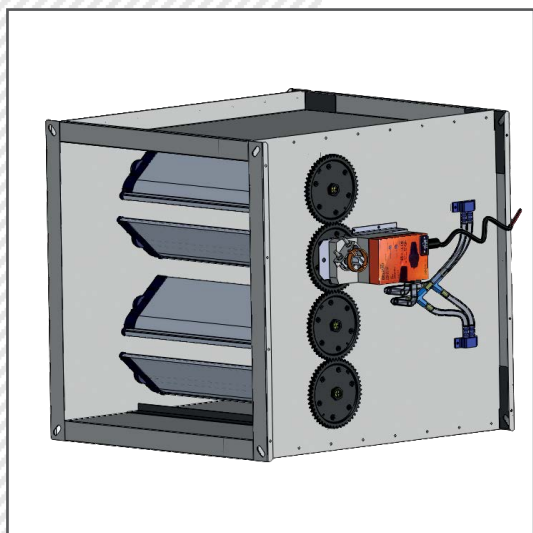

Characteristics

Rectangular variable air volume control dampers enable the regulation of supply or exhaust air volume in ventilation systems. They consist of a casing made of galvanized steel sheet, aluminium blades, a measuring device and electric actuator. The actuator rotates the flap, which is provided with a rubber seal. Depending on project requirements the damper can be controlled via temperature sensors, air flow sensors or pressure sensors placed in a room or ventilation ducts. Differential measurement values are sent from a measuring device to the motor actuator where they are compared with the reference signal. Depending on a signal difference, the actuator closes or opens therefore ensuring optimal air volume in the room.

Each unit is exactly parameterised according to customer's specifications.

SYMBOL	DESCRIPTION
D_p	Pressure drop [PA]
Q	Airflow rate [m ³ /h]
L_w	Sound power level [dB(A)]

Dimensions

Without insulation

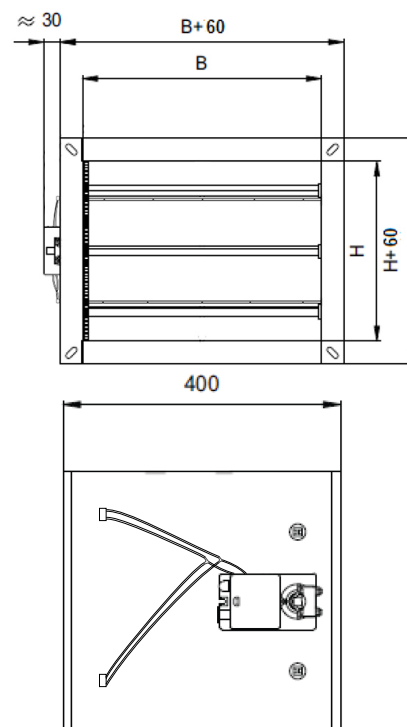

With insulation

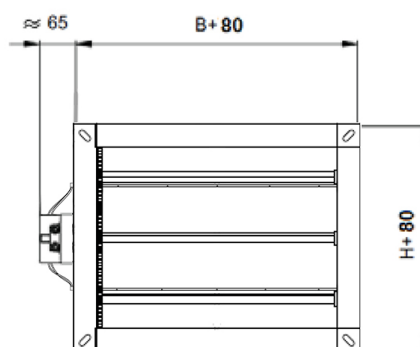

ERP-6

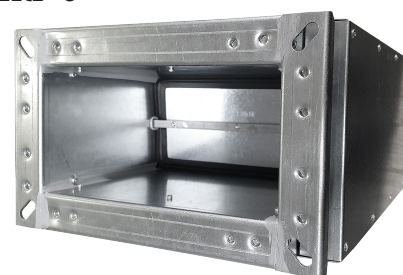

ERP-7



Dimensions, effective areas, Air flow (max. and min.)

B [mm]	H [mm]	A _{ef} [mm]	V _{min} [m ³ /h]	V _{max} [m ³ /h]
200	100	0,0170	144	720
300	100	0,0255	216	1080
400	100	0,0340	288	1440
500	100	0,0425	360	1800
600	100	0,0510	432	2160
200	200	0,0340	288	1440
300	200	0,0510	432	2160
400	200	0,0680	576	2880
500	200	0,0850	720	3600
600	200	0,1020	864	4320
700	200	0,1190	1008	5040
800	200	0,1360	1152	5760
300	300	0,0765	648	3240
400	300	0,1020	864	4320
500	300	0,1275	1080	5400
600	300	0,1530	1296	6480
700	300	0,1785	1512	7560
800	300	0,1530	1728	8640
900	300	0,1785	1944	9720
1000	300	0,2040	2160	10800
400	400	0,1360	1152	5760
500	400	0,1700	1440	7200
600	400	0,2040	1728	8640
700	400	0,2380	2016	10080
800	400	0,2720	2304	11520

B [mm]	H [mm]	A _{ef} [mm]	V _{min} [m ³ /h]	V _{max} [m ³ /h]
900	400	0,2380	2592	12960
200	500	0,0850	720	3600
300	500	0,1275	1080	5400
400	500	0,1700	1440	7200
500	500	0,2125	1800	9000
600	500	0,2550	2160	10800
700	500	0,2975	2520	12600
800	500	0,3400	2880	14400
900	500	0,3825	3240	16200
1000	500	0,4250	3600	18000
600	600	0,3060	2592	12960
700	600	0,3570	3024	15120
800	600	0,4080	3456	17280
900	600	0,4590	3888	19440
1000	600	0,5100	4320	21600
700	700	0,4165	3528	17640
800	700	0,4760	4032	20160
900	700	0,5355	4536	22680
1000	700	0,5950	5040	25200
800	800	0,5440	4608	23040
900	800	0,6120	5184	25920
1000	800	0,6800	5760	28800
900	900	0,6885	5832	29160
1000	900	0,7650	6480	32400
1000	1000	0,8500	7200	36000

Installation rules:

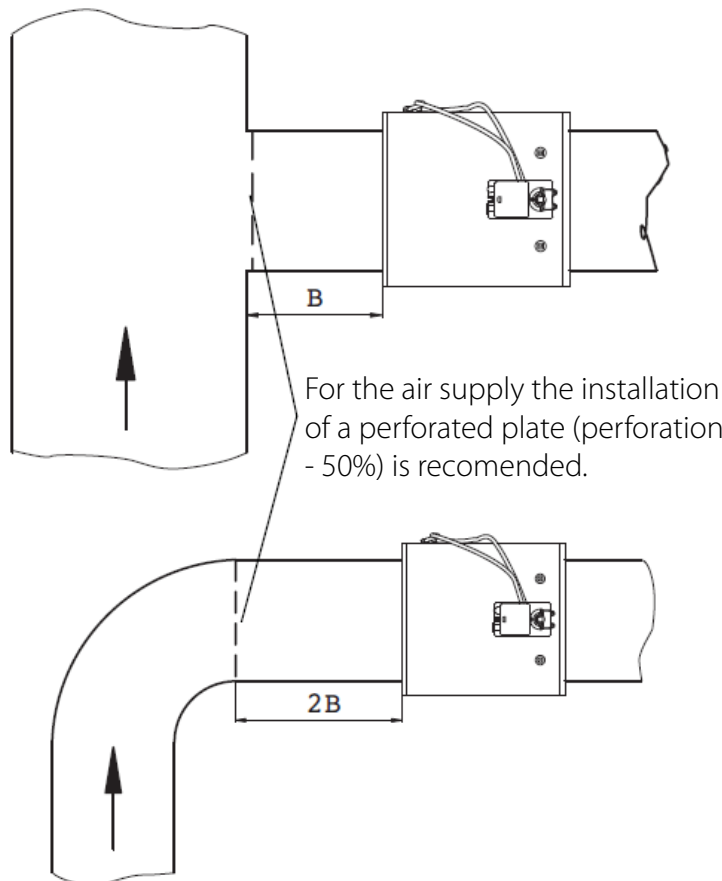

Generated noise: $D_p = 125, 250 \text{ Pa}$

Model		$D_p = 125 \text{ Pa}$										$D_p = 250 \text{ Pa}$							
		Sound power L_w [dB]										Sound power L_w [dB]							
B x H [mm]	Q [m³/h]	63 Hz	125 Hz	250 Hz	500 Hz	1000 Hz	2000 Hz	4000 Hz	8000 Hz	$L_{w,A}$ [dBA]	63 Hz	125 Hz	250 Hz	500 Hz	1000 Hz	2000 Hz	4000 Hz	8000 Hz	$L_{w,A}$ [dBA]
		1000x400	2880	66	60	59	52	55	58	52	50	62	68	65	63	56	58	65	59
5760	71		66	61	53	56	59	55	51	64	73	69	66	60	61	65	61	59	69
11520	79		75	69	56	58	63	59	56	68	81	78	73	64	64	67	65	63	73
14400	82		77	71	58	59	64	59	57	70	84	81	76	66	65	68	66	64	75
1000x600	4320	69	62	61	52	54	61	53	52	64	70	66	65	58	59	65	62	59	69
	8640	73	68	63	54	56	62	55	54	66	74	72	67	61	62	68	62	59	72
	17280	82	76	70	58	59	65	60	59	70	82	80	76	66	65	69	66	64	75
	21600	86	79	73	59	60	65	62	59	71	86	84	79	66	65	69	67	65	76
1000x800	5760	69	65	62	52	56	61	54	52	65	71	67	66	59	61	66	62	59	70
	11520	75	68	65	55	56	63	56	54	67	76	72	71	62	63	68	62	61	72
	23040	84	77	72	58	59	66	61	59	71	83	82	78	66	65	71	66	65	76
	28800	86	82	73	59	61	67	62	61	73	86	85	79	68	66	70	68	66	77
1000x1000	7200	71	65	62	54	55	62	53	55	65	72	69	67	61	62	67	62	59	71
	14400	77	69	67	55	57	63	58	56	67	77	74	71	63	64	69	64	62	73
	28800	85	78	73	59	61	67	61	61	72	86	83	79	66	66	72	67	65	77
	36000	87	83	76	59	61	68	63	62	74	88	86	82	68	67	71	68	66	78
800x200	1152	61	56	54	49	53	55	49	45	59	62	60	57	56	58	61	57	54	65
	2304	65	61	56	51	54	56	51	48	61	67	64	61	57	59	62	58	55	66
	4608	74	71	64	54	57	58	55	52	64	75	73	67	62	63	64	62	58	70
	5760	77	73	66	56	59	60	57	53	66	78	75	71	63	63	65	62	60	71
800x400	2304	65	59	56	51	53	58	52	49	62	67	62	60	57	58	63	59	55	67
	4608	69	65	60	52	56	59	54	51	63	71	67	65	59	61	64	60	58	69
	9216	77	74	68	56	58	62	57	56	67	79	76	72	64	64	66	63	62	72
	11520	81	76	69	57	60	63	59	56	69	82	79	75	66	65	67	65	63	74
800x600	3456	66	61	59	51	55	59	53	50	63	68	64	63	58	59	64	61	57	68
	6912	72	66	63	54	56	60	55	53	64	73	69	67	61	62	66	62	59	70
	13824	81	76	69	56	60	64	58	57	69	81	78	75	66	64	69	65	63	74
	17280	83	78	72	58	61	63	60	59	70	84	82	77	67	66	68	66	65	75
800x800	4608	67	63	61	51	55	61	53	51	64	71	66	65	58	59	65	61	58	69
	9216	73	67	65	54	56	61	55	54	65	75	71	69	61	62	68	62	59	72
	18432	82	76	72	57	58	65	60	59	70	83	81	76	66	65	69	65	64	75
	23040	85	81	74	58	59	66	61	59	72	86	83	78	67	66	69	66	65	76
600x600	2592	64	60	57	51	53	59	52	48	62	67	63	61	57	58	63	59	57	67
	5184	69	65	61	54	55	60	54	51	64	72	68	65	59	61	56	61	58	67
	10368	78	75	68	56	59	63	57	55	68	79	78	73	64	63	68	64	62	73
	12960	82	78	69	58	59	63	59	57	69	83	80	76	65	64	68	65	63	74



Generated noise: $D_p = 500, 1000 \text{ Pa}$

Model		$D_p = 500 \text{ Pa}$									$D_p = 1000 \text{ Pa}$								
		Sound power L_w [dB]									Sound power L_w [dB]								
B x H [mm]	Q [m ³ /h]	63 Hz	125 Hz	250 Hz	500 Hz	1000 Hz	2000 Hz	4000 Hz	8000 Hz	$L_{w,A}$ [dBA]	63 Hz	125 Hz	250 Hz	500 Hz	1000 Hz	2000 Hz	4000 Hz	8000 Hz	$L_{w,A}$ [dBA]
1000x400	2880	73	67	71	65	65	73	69	68	77	73	67	70	69	69	78	77	76	83
	5760	76	72	74	68	67	73	71	68	78	79	76	79	75	73	79	78	77	84
	11520	85	81	85	74	70	73	71	71	81	85	87	89	83	77	80	78	78	87
	14400	88	85	86	76	71	74	71	72	82	89	90	72	84	78	80	78	79	87
1000x600	4320	75	69	75	66	66	74	71	68	78	74	72	74	73	70	80	78	76	84
	8640	79	73	79	69	67	74	72	71	79	81	79	83	78	75	82	78	77	86
	17280	87	83	88	74	71	75	72	73	83	88	89	92	84	78	82	79	78	89
	21600	89	86	91	76	72	75	72	73	85	88	92	95	86	80	82	79	79	91
1000x800	5760	76	71	77	68	68	74	72	69	79	74	71	76	72	72	80	79	77	85
	11520	81	75	81	72	68	76	72	69	80	81	82	86	79	75	81	79	77	86
	23040	89	85	91	76	72	77	74	72	85	87	90	96	85	79	83	79	78	91
	28800	92	88	94	78	73	76	74	73	87	90	93	99	89	80	83	79	79	93
1000x1000	7200	77	72	79	69	68	76	73	69	80	75	72	79	74	72	82	79	76	86
	14400	82	75	84	73	69	76	73	71	81	81	82	89	80	76	82	80	78	88
	28800	89	87	93	77	73	77	74	74	87	89	92	97	88	80	83	80	78	92
	36000	93	89	95	80	74	77	74	74	88	92	95	700	89	81	83	80	79	691
800x200	1152	69	65	65	63	66	69	67	65	74	69	64	64	65	68	75	76	74	81
	2304	72	68	68	63	66	68	68	66	74	76	72	72	70	72	76	76	75	82
	4608	81	78	78	69	69	71	69	68	77	82	83	82	77	75	76	77	76	84
	5760	83	81	79	71	69	71	69	68	78	84	83	83	79	75	77	77	77	84
800x400	2304	72	66	69	65	66	72	69	66	76	70	66	69	68	69	77	77	74	82
	4608	76	70	74	67	67	72	70	68	77	77	76	78	74	73	78	78	77	84
	9216	84	81	84	72	70	73	71	69	80	84	86	88	82	77	79	78	77	86
	11520	86	85	86	74	71	72	71	71	81	87	89	92	83	78	79	78	77	88
800x600	3456	74	67	73	65	66	73	71	68	77	72	69	73	70	70	79	78	76	84
	6912	78	72	78	69	67	73	72	69	78	79	78	82	77	74	80	79	77	85
	13824	86	83	87	73	72	75	72	72	82	86	89	91	84	78	80	79	77	88
	17280	89	85	89	76	72	75	72	72	84	89	92	94	85	79	82	79	78	90
800x800	4608	75	69	76	67	67	73	71	68	78	73	70	74	72	72	79	79	76	84
	9216	80	73	81	69	67	75	71	68	80	79	80	84	79	74	80	79	77	86
	18432	87	84	89	75	71	76	73	72	84	86	89	94	84	78	81	79	78	89
	23040	90	88	93	76	72	75	73	72	86	89	93	96	87	79	83	79	79	91
600x600	2592	71	66	70	65	66	71	69	67	76	70	68	69	68	69	78	77	75	83
	5184	76	72	75	67	66	72	71	68	77	78	76	79	75	74	79	78	76	84
	10368	84	81	84	72	71	74	71	71	81	85	86	88	82	77	79	78	77	86
	12960	87	84	87	75	71	74	71	71	82	87	89	92	83	79	80	78	78	88

Generated noise: $D_p = 125, 250 \text{ Pa}$

Model		$D_p = 125 \text{ Pa}$										$D_p = 250 \text{ Pa}$							
B x H [mm]	Q [m³/h]	Sound power L_w [dB]										Sound power L_w [dB]							
		63 Hz	125 Hz	250 Hz	500 Hz	1000 Hz	2000 Hz	4000 Hz	8000 Hz	L_{wA} [dBA]	63 Hz	125 Hz	250 Hz	500 Hz	1000 Hz	2000 Hz	4000 Hz	8000 Hz	L_{wA} [dBA]
600x400	1728	62	58	55	50	51	56	51	46	60	65	61	59	56	57	62	58	55	66
	3456	67	63	59	53	55	58	52	49	62	69	67	63	58	59	94	58	57	95
	6912	76	73	65	56	58	61	56	54	66	78	76	69	63	63	65	62	61	71
	8640	78	76	67	56	59	62	58	55	68	81	78	73	65	64	66	64	62	73
600x200	864	58	55	51	49	52	53	48	43	58	61	58	55	55	56	59	56	53	64
	1728	63	59	55	51	53	55	49	46	59	65	63	58	57	59	61	56	54	65
	3456	72	69	62	55	57	58	54	50	64	73	72	65	61	62	63	61	58	69
	4320	75	72	64	57	58	59	56	50	65	76	75	68	63	63	64	61	58	70
600x100	432	54	53	48	48	49	51	46	40	55	58	57	52	53	54	57	53	51	61
	864	58	58	51	49	52	53	46	43	57	62	59	55	54	56	59	55	52	63
	1728	67	66	57	53	55	55	52	46	61	71	68	62	59	60	61	58	55	67
	2160	71	69	59	55	56	56	53	47	62	74	72	65	61	61	61	59	57	68
400x400	1152	59	56	53	49	50	54	49	44	58	63	59	57	55	56	60	57	55	65
	2304	64	61	57	52	54	56	51	47	61	67	64	61	57	58	62	58	56	66
	4608	72	71	64	54	57	59	54	52	64	76	74	67	62	62	63	62	60	70
	5760	76	73	66	56	58	59	56	52	66	79	76	71	64	62	65	63	61	71
400x200	576	56	53	50	49	51	52	45	42	56	59	56	52	54	56	57	54	51	62
	1152	59	58	53	49	52	53	48	44	58	63	61	57	56	57	59	56	52	64
	2304	69	68	59	54	56	56	51	48	62	72	69	64	59	61	62	59	57	68
	2880	72	70	62	56	57	57	54	49	63	75	73	66	62	62	62	61	57	69
400x100	288	51	51	46	48	50	50	44	39	55	56	54	49	52	53	55	53	49	60
	576	55	56	49	48	51	51	45	41	56	60	57	53	53	56	57	54	50	62
	1152	64	64	56	52	54	53	49	45	59	68	67	59	58	59	59	57	55	65
	1440	68	68	57	54	55	54	51	46	61	71	69	63	60	60	58	58	56	66
200x200	288	52	51	45	47	50	49	44	38	54	56	52	47	52	53	55	53	48	60
	576	56	54	49	49	51	49	46	41	55	61	56	52	53	56	57	53	50	62
	1152	65	65	55	53	55	52	49	45	59	68	66	59	57	59	60	57	53	65
	1440	68	68	57	55	56	54	52	46	61	72	68	62	60	60	60	59	55	66
200x100	144	47	48	42	47	48	47	41	36	52	53	51	44	49	52	53	51	47	58
	288	51	52	46	47	50	48	43	38	54	57	54	48	51	54	55	51	47	60
	576	60	61	51	51	53	49	58	52	61	65	63	54	56	57	57	55	52	63
	720	64	65	53	52	54	51	49	43	59	68	66	58	58	58	56	56	53	64



Generated noise: $D_p = 500, 1000 \text{ Pa}$

Model		$D_p = 500 \text{ Pa}$									$D_p = 1000 \text{ Pa}$								
B x H [mm]	Q [m ³ /h]	Sound power L_w [dB]									Sound power L_w [dB]								
		63 Hz	125 Hz	250 Hz	500 Hz	1000 Hz	2000 Hz	4000 Hz	8000 Hz	$L_w A$ [dBA]	63 Hz	125 Hz	250 Hz	500 Hz	1000 Hz	2000 Hz	4000 Hz	8000 Hz	$L_w A$ [dBA]
600x400	1728	69	65	67	64	65	70	68	66	75	69	64	66	66	68	76	76	74	81
	3456	73	69	71	66	66	71	69	66	76	76	74	75	72	72	77	77	76	83
	6912	82	79	81	72	69	72	69	68	79	83	84	85	80	76	79	77	77	85
	8640	85	83	82	74	69	72	69	69	79	86	87	89	82	77	78	77	77	86
600x200	864	66	63	61	61	63	67	66	63	72	68	62	60	62	66	74	75	74	80
	1728	69	66	65	63	65	68	68	64	74	74	71	69	68	70	76	75	76	81
	3456	79	76	75	67	67	70	69	67	76	82	80	79	76	74	75	76	76	83
	4320	81	81	76	69	68	69	68	68	76	84	82	81	77	74	77	77	77	84
600x100	432	63	59	55	58	62	65	64	62	70	65	57	55	58	64	72	75	73	79
	864	65	64	58	59	63	65	66	63	71	72	66	64	65	69	73	75	75	80
	1728	75	74	68	65	65	66	67	65	73	80	76	73	72	72	73	74	75	80
	2160	76	78	71	67	67	68	67	65	74	81	78	74	72	72	74	75	76	81
400x400	1152	67	63	62	62	64	68	67	65	73	68	62	62	65	67	75	75	74	80
	2304	72	67	66	64	65	68	68	66	74	75	73	71	70	72	76	76	77	82
	4608	79	78	76	70	69	70	68	68	77	83	82	81	78	75	77	76	77	84
	5760	83	81	79	72	68	70	69	68	78	85	85	84	80	76	77	76	78	85
400x200	576	64	61	57	58	62	65	65	63	71	67	59	56	60	66	73	74	74	79
	1152	67	65	61	61	63	65	67	64	72	73	68	65	67	69	74	74	76	80
	2304	77	74	71	65	67	68	68	65	74	80	79	75	73	73	74	75	77	82
	2880	79	79	72	67	66	68	68	66	75	83	80	76	74	73	76	76	77	83
400x100	288	61	58	52	56	61	63	63	61	69	63	55	50	57	63	71	73	73	78
	576	63	62	54	58	62	63	64	62	70	72	64	59	63	67	72	73	74	79
	1152	73	72	64	62	65	65	66	63	72	78	74	69	69	71	72	73	75	79
	1440	75	76	66	64	66	65	66	65	73	81	76	70	70	72	73	73	76	80
200x200	288	60	58	51	56	61	64	64	61	70	63	55	51	56	63	70	73	73	77
	576	64	61	55	58	62	63	64	62	70	71	64	60	62	67	71	73	74	78
	1152	73	71	65	62	65	66	66	63	72	78	74	69	69	72	72	74	75	80
	1440	75	76	66	65	65	66	66	64	73	80	86	70	70	72	73	74	76	81
200x100	144	57	55	46	52	58	62	62	59	67	61	52	44	53	61	68	72	72	76
	288	60	58	49	55	59	62	63	59	68	68	61	54	59	65	68	83	84	87
	576	69	69	58	59	63	62	64	62	70	76	70	63	66	69	69	72	75	78
	720	71	73	60	62	64	63	64	62	70	78	72	64	66	69	69	72	76	79

Radiated noise: $D_p = 125, 250 \text{ Pa}$

Model		$D_p = 125 \text{ Pa}$									$D_p = 250 \text{ Pa}$								
		Sound power L_w [dB]									Sound power L_w [dB]								
B x H [mm]	Q [m³/h]	63 Hz	125 Hz	250 Hz	500 Hz	1000 Hz	2000 Hz	4000 Hz	8000 Hz	L_w A [dBA]	63 Hz	125 Hz	250 Hz	500 Hz	1000 Hz	2000 Hz	4000 Hz	8000 Hz	L_w A [dBA]
1000x400	2880	61	57	54	49	53	56	50	48	60	61	57	53	46	46	48	43	42	53
	5760	68	63	56	46	44	46	39	38	54	70	66	60	50	49	51	46	45	58
	11520	80	74	69	56	59	63	59	56	68	77	76	67	54	51	54	49	48	64
	14400	80	74	65	48	47	50	45	43	62	80	78	69	56	53	54	51	49	66
1000x600	4320	64	58	56	49	53	59	51	48	62	62	59	55	47	47	51	44	43	55
	8640	71	64	57	46	44	47	40	40	55	71	68	62	52	49	53	48	45	60
	17280	79	74	64	49	48	50	45	45	62	79	77	69	56	53	56	51	49	66
	21600	83	76	66	49	48	51	47	46	64	83	80	72	58	53	55	52	51	68
1000x800	5760	65	59	57	51	53	59	53	50	62	64	61	56	48	47	52	46	43	57
	11520	71	66	59	46	45	48	51	40	57	73	69	64	53	51	54	48	46	61
	23040	81	74	65	49	48	51	45	46	62	80	78	72	57	54	56	51	51	67
	28800	84	78	67	51	49	53	46	46	65	83	81	73	58	54	56	53	52	69
1000x1000	7200	66	61	59	52	54	61	53	51	64	66	62	58	49	48	52	46	44	57
	14400	74	66	61	45	45	49	43	42	57	74	70	65	54	52	55	49	48	62
	28800	81	75	66	50	49	52	47	47	63	82	79	73	57	55	57	52	52	68
	36000	85	79	69	51	49	54	47	47	66	84	83	76	59	54	57	53	53	71
800x200	1152	52	49	44	38	39	39	32	29	45	56	53	47	44	44	45	40	38	50
	2304	61	57	51	41	41	41	36	34	49	64	60	55	48	47	47	43	41	54
	4608	71	67	57	46	46	45	39	38	55	72	69	62	52	51	51	46	45	60
	5760	72	69	59	47	46	46	41	39	57	75	72	64	54	52	51	46	45	61
800x400	2304	56	52	48	39	41	42	34	33	47	58	56	51	45	45	48	43	41	53
	4608	65	61	54	44	44	45	38	36	52	68	65	58	51	48	51	45	43	57
	9216	74	70	62	47	47	48	42	41	59	76	74	65	55	52	53	48	48	63
	11520	77	74	63	48	48	49	43	42	61	79	77	68	57	53	54	49	48	65
800x600	3456	62	56	55	49	54	58	49	48	61	61	58	54	47	47	49	43	41	54
	6912	69	63	57	44	43	47	39	38	54	70	67	61	51	49	53	47	45	59
	13824	78	72	64	47	47	49	44	44	60	78	75	68	57	53	55	50	48	65
	17280	81	75	66	49	49	50	45	44	63	82	79	72	58	54	55	51	49	68
800x800	4608	60	56	52	41	41	45	36	35	50	65	63	62	56	58	65	59	56	68
	9216	69	65	59	45	44	47	41	40	55	72	69	64	52	49	54	47	45	61
	18432	78	74	65	48	47	51	44	44	62	80	78	71	56	53	56	49	50	67
	23040	82	77	68	49	48	52	46	46	65	83	81	72	58	54	55	52	51	68
600x600	2592	58	53	47	39	41	43	33	32	48	60	57	52	45	45	49	43	41	53
	5184	66	63	54	45	43	46	38	37	53	69	66	59	52	49	53	45	44	58
	10368	76	71	62	48	47	49	42	41	59	77	75	66	56	51	54	49	48	64
	12960	79	74	63	48	47	48	45	43	61	80	79	69	57	53	54	50	49	66



Radiated noise: $D_p = 500, 1000 \text{ Pa}$

Model		$D_p = 500 \text{ Pa}$										$D_p = 1000 \text{ Pa}$								
		Sound power L_w [dB]										Sound power L_w [dB]								
B x H [mm]	Q [m³/h]	63 Hz	125 Hz	250 Hz	500 Hz	1000 Hz	2000 Hz	4000 Hz	8000 Hz	L_w A [dBA]	63 Hz	125 Hz	250 Hz	500 Hz	1000 Hz	2000 Hz	4000 Hz	8000 Hz	L_w A [dBA]	
1000x400	2880	65	58	59	53	52	58	54	53	62	68	64	64	60	58	64	63	62	69	
	5760	74	68	68	59	54	59	56	54	65	75	74	73	66	61	65	63	63	72	
	11520	82	78	78	65	58	60	56	57	72	83	84	83	73	65	66	63	64	78	
	14400	85	53	81	66	59	60	55	58	74	85	87	86	76	66	67	63	65	80	
1000x600	4320	68	61	63	54	53	58	56	54	63	69	68	67	63	58	67	63	62	71	
	8640	76	71	72	61	55	59	57	57	67	79	77	77	69	63	67	65	63	74	
	17280	83	81	82	65	59	62	57	58	75	84	87	87	76	66	68	95	64	96	
	21600	87	84	86	67	60	63	57	59	78	87	89	89	78	68	69	65	65	83	
1000x800	5760	68	63	66	57	54	59	57	55	65	70	68	71	63	60	66	65	62	72	
	11520	77	72	76	62	57	62	56	55	70	78	79	80	71	64	67	65	64	76	
	23040	86	82	85	68	59	62	59	59	77	85	88	89	77	67	68	65	65	82	
	28800	89	86	87	69	61	62	59	59	80	88	91	92	79	69	69	65	66	85	
1000x1000	7200	72	67	75	66	66	75	72	69	79	72	69	73	65	61	67	65	63	73	
	14400	79	73	78	63	58	62	58	56	72	78	79	83	72	65	68	66	64	77	
	28800	87	83	87	69	61	63	58	59	79	86	89	92	79	68	69	66	65	85	
	36000	90	87	90	72	63	64	59	60	82	89	92	94	81	70	69	65	64	87	
800x200	1152	59	55	52	49	51	54	52	49	59	67	60	58	55	55	62	62	61	68	
	2304	69	64	62	55	54	55	53	52	62	72	70	66	62	60	62	61	62	69	
	4608	78	75	72	59	57	57	54	53	67	79	80	76	69	63	62	63	62	73	
	5760	79	78	73	61	57	57	55	54	68	82	81	79	69	65	64	62	63	75	
800x400	2304	64	58	59	53	51	56	55	51	61	67	64	64	59	58	63	62	60	68	
	4608	73	67	67	58	55	58	56	54	65	75	74	73	65	61	65	63	62	72	
	9216	81	78	78	63	58	58	55	56	71	81	84	83	72	66	65	64	63	77	
	11520	84	81	79	66	59	59	56	57	73	85	87	86	74	67	66	64	63	80	
800x600	3456	67	59	63	54	53	58	56	52	63	68	67	67	62	58	65	64	62	70	
	6912	75	69	72	59	56	58	57	55	67	77	75	76	68	63	66	65	63	73	
	13824	83	80	80	64	59	61	57	58	73	83	86	85	75	66	66	65	63	79	
	17280	86	83	84	67	60	62	57	59	77	86	89	89	77	67	68	65	64	82	
800x800	4608	68	62	66	54	53	59	56	54	64	69	68	69	63	59	66	65	62	71	
	9216	77	71	74	61	55	61	56	55	69	77	78	78	70	62	66	65	64	74	
	18432	85	81	84	65	59	62	57	57	76	84	87	88	76	66	67	95	64	96	
	23040	88	85	86	68	59	62	58	58	79	87	90	91	78	68	69	64	66	84	
600x600	2592	65	58	59	53	52	57	54	52	62	67	65	64	59	68	65	62	62	72	
	5184	73	68	68	59	55	57	56	55	65	76	74	73	67	62	65	63	63	72	
	10368	81	78	77	64	59	60	56	57	71	82	84	83	72	66	65	63	64	77	
	12960	84	82	81	65	59	60	57	58	74	85	86	86	75	67	67	64	65	80	

Radiated noise: $D_p = 125, 250 \text{ Pa}$

Model		$D_p = 125 \text{ Pa}$										$D_p = 250 \text{ Pa}$							
B x H [mm]	Q [m³/h]	Sound power L_w [dB]										Sound power L_w [dB]							
		63 Hz	125 Hz	250 Hz	500 Hz	1000 Hz	2000 Hz	4000 Hz	8000 Hz	$L_{w,A}$ [dBA]	63 Hz	125 Hz	250 Hz	500 Hz	1000 Hz	2000 Hz	4000 Hz	8000 Hz	$L_{w,A}$ [dBA]
600x400	1728	55	52	46	39	39	41	33	31	46	58	55	49	45	45	47	41	39	52
	3456	63	61	52	44	43	44	37	34	51	67	64	56	49	48	49	44	43	56
	6912	72	69	60	46	45	47	42	39	57	75	73	64	54	51	52	48	47	62
	8640	76	72	62	47	46	48	43	41	59	78	76	67	55	52	53	49	48	64
600x200	864	51	48	42	38	39	38	31	26	44	55	52	45	42	42	45	39	37	49
	1728	59	56	49	42	40	40	34	32	48	63	59	53	48	46	46	42	39	53
	3456	68	67	55	46	44	43	38	36	54	71	68	59	52	49	49	46	44	58
	4320	69	68	57	46	45	45	39	36	55	73	71	62	53	51	49	46	44	60
600x100	432	45	44	38	37	36	35	29	24	41	51	48	42	41	42	42	37	35	47
	864	58	58	51	49	51	52	46	43	57	60	57	49	45	45	45	39	38	51
	1728	64	62	51	45	43	40	36	33	51	68	66	56	49	48	47	44	41	56
	2160	66	65	52	45	44	41	36	34	52	69	68	56	51	49	47	43	42	57
400x400	1152	52	49	44	39	39	39	32	28	45	56	52	48	43	43	45	41	38	50
	2304	60	59	51	42	41	41	36	33	49	65	62	55	49	46	47	43	42	54
	4608	69	68	58	45	44	44	40	38	55	73	71	61	52	49	49	47	46	59
	5760	73	70	59	47	46	46	40	38	57	75	74	64	55	51	51	48	46	62
400x200	576	48	46	39	38	38	36	28	24	43	53	49	43	42	42	43	38	35	48
	1152	61	61	49	43	42	38	34	31	49	61	58	51	46	45	44	41	39	52
	2304	65	64	53	45	44	42	37	33	52	69	66	58	51	49	48	44	42	57
	2880	67	65	55	45	44	42	38	34	53	71	69	59	52	49	48	44	42	58
400x100	288	43	43	36	36	35	33	27	22	40	49	46	39	39	41	39	37	34	46
	576	52	53	43	39	38	37	29	27	44	58	54	47	44	44	42	39	37	49
	1152	60	60	49	44	42	38	35	31	49	66	64	53	48	47	45	43	41	54
	1440	63	61	50	45	42	39	36	32	50	67	66	54	49	48	45	42	41	55
200x200	288	44	44	35	36	36	33	27	22	40	50	46	37	39	39	41	37	34	46
	576	52	51	42	39	38	35	31	27	43	58	53	46	45	44	43	38	36	50
	1152	62	62	49	43	42	38	35	31	50	66	63	52	49	47	46	43	39	54
	1440	63	63	51	44	42	39	36	32	51	68	65	56	50	48	46	44	40	55
200x100	144	38	39	33	36	35	31	24	19	39	46	42	34	38	39	37	35	31	44
	288	47	49	39	38	37	34	28	24	42	55	51	42	42	42	41	36	34	47
	576	56	57	46	43	41	35	33	28	47	63	59	49	46	44	43	41	38	51
	720	58	59	47	44	42	36	33	29	48	64	62	51	48	46	43	41	38	53



Radiated noise: $D_p = 500, 1000 \text{ Pa}$

L_w [dBA]		$D_p = 500 \text{ Pa}$										$D_p = 1000 \text{ Pa}$							
B x H [mm]	Q [m ³ /h]	Sound power L_w [dB]										Sound power L_w [dB]							
		63 Hz	125 Hz	250 Hz	500 Hz	1000 Hz	2000 Hz	4000 Hz	8000 Hz	L_w A [dBA]	63 Hz	125 Hz	250 Hz	500 Hz	1000 Hz	2000 Hz	4000 Hz	8000 Hz	L_w A [dBA]
600x400	1728	61	57	56	51	50	56	54	51	61	66	62	61	58	57	62	61	60	67
	3456	71	66	65	57	54	56	55	53	63	73	72	69	64	61	64	62	63	70
	6912	79	76	75	63	57	57	55	55	69	81	82	79	71	64	65	63	64	75
	8640	82	81	76	65	58	58	55	56	71	84	85	83	73	65	65	63	64	78
600x200	864	58	54	49	48	49	53	52	48	58	64	59	55	53	54	60	61	60	66
	1728	67	64	58	54	53	54	52	61	63	71	68	64	59	58	62	60	61	68
	3456	76	74	68	59	56	56	54	52	65	78	77	74	66	62	62	61	62	71
	4320	77	76	70	60	57	57	54	53	67	81	79	75	68	62	63	62	62	72
600x100	432	55	51	43	45	48	51	49	47	56	61	55	48	49	52	58	59	59	64
	864	63	61	53	51	51	52	50	49	58	69	64	57	56	57	58	59	60	65
	1728	72	71	62	55	53	52	52	51	62	76	74	67	63	60	59	60	61	68
	2160	73	73	65	58	55	53	52	51	63	79	75	69	64	60	61	60	62	69
400x400	1152	59	55	52	49	49	54	53	49	59	65	59	57	55	55	61	60	61	66
	2304	69	65	61	54	53	55	54	52	62	72	69	65	62	59	62	61	62	69
	4608	77	75	71	61	56	55	53	53	66	79	80	75	68	63	64	61	63	73
	5760	80	79	73	63	56	55	54	55	69	82	82	78	71	65	64	61	64	75
400x200	576	56	52	46	46	48	51	51	48	57	63	57	50	52	53	59	59	61	65
	1152	65	61	54	52	52	52	52	49	59	71	66	59	57	58	60	59	61	66
	2304	74	72	65	56	54	53	52	51	63	77	76	69	64	62	60	60	62	69
	2880	76	74	66	58	55	54	53	52	64	80	77	71	65	61	62	60	62	70
400x100	288	53	49	39	43	47	49	49	46	55	61	52	45	47	51	57	58	59	63
	576	61	59	48	48	50	50	50	48	57	68	62	53	54	55	57	58	60	64
	1152	70	69	59	54	53	50	50	49	60	76	71	63	61	59	58	58	61	67
	1440	71	71	60	55	54	52	52	50	61	78	73	65	62	59	59	58	63	68
200x200	288	52	49	40	43	47	49	49	46	55	61	52	45	47	51	57	58	59	63
	576	61	59	49	49	50	50	50	48	57	68	62	53	54	55	57	58	60	64
	1152	69	68	59	54	53	52	51	49	60	74	72	63	61	59	57	59	61	67
	1440	72	72	59	55	53	52	51	50	61	76	73	64	62	59	58	60	61	67
200x100	144	49	46	34	40	45	46	46	44	52	58	48	39	43	49	53	57	58	62
	288	57	56	43	45	48	48	48	46	55	66	57	48	50	54	54	58	59	63
	576	66	66	53	51	51	49	49	48	58	72	67	57	56	57	56	58	60	65
	720	67	68	54	52	52	49	49	48	58	75	69	59	58	58	57	58	61	66

Generated noise: $D_p = 125, 250 \text{ Pa}$

Model		$D_p = 125 \text{ Pa}$										$D_p = 250 \text{ Pa}$							
		Sound power L_w [dB]										Sound power L_w [dB]							
B x H [mm]	Q [m³/h]	63 Hz	125 Hz	250 Hz	500 Hz	1000 Hz	2000 Hz	4000 Hz	8000 Hz	$L_{w,A}$ [dBA]	63 Hz	125 Hz	250 Hz	500 Hz	1000 Hz	2000 Hz	4000 Hz	8000 Hz	$L_{w,A}$ [dBA]
1000x400	2880	66	60	59	52	55	58	52	50	62	68	65	63	56	58	65	59	58	68
	5760	71	66	61	53	56	59	55	51	64	73	69	66	60	61	65	61	59	69
	11520	79	75	69	56	58	63	59	56	68	81	78	73	64	64	67	65	63	73
	14400	82	77	71	58	59	64	59	57	70	84	81	76	66	65	68	66	64	75
1000x600	4320	69	62	61	52	54	61	53	52	64	70	66	65	58	59	65	62	59	69
	8640	73	68	63	54	56	62	55	54	66	74	72	67	61	62	68	62	59	72
	17280	82	76	70	58	59	65	60	59	70	82	80	76	66	65	69	66	64	75
	21600	86	79	73	59	60	65	62	59	71	86	84	79	66	65	69	67	65	76
1000x800	5760	69	65	62	52	56	61	54	52	65	71	67	66	59	61	66	62	59	70
	11520	75	68	65	55	56	63	56	54	67	76	72	71	62	63	68	62	61	72
	23040	84	77	72	58	59	66	61	59	71	83	82	78	66	65	71	66	65	76
	28800	86	82	73	59	61	67	62	61	73	86	85	79	68	66	70	68	66	77
1000x1000	7200	71	65	62	54	55	62	53	55	65	72	69	67	61	62	67	62	59	71
	14400	77	69	67	55	57	63	58	56	67	77	74	71	63	64	69	64	62	73
	28800	85	78	73	59	61	67	61	61	72	86	83	79	66	66	72	67	65	77
	36000	87	83	76	59	61	68	63	62	74	88	86	82	68	67	71	68	66	78
800x200	1152	61	56	54	49	53	55	49	45	59	62	60	57	56	58	61	57	54	65
	2304	65	61	56	51	54	56	51	48	61	67	64	61	57	59	62	58	55	66
	4608	74	71	64	54	57	58	55	52	64	75	73	67	62	63	64	62	58	70
	5760	77	73	66	56	59	60	57	53	66	78	75	71	63	63	65	62	60	71
800x400	2304	65	59	56	51	53	58	52	49	62	67	62	60	57	58	63	59	55	67
	4608	69	65	60	52	56	59	54	51	63	71	67	65	59	61	64	60	58	69
	9216	77	74	68	56	58	62	57	56	67	79	76	72	64	64	66	63	62	72
	11520	81	76	69	57	60	63	59	56	69	82	79	75	66	65	67	65	63	74
800x600	3456	66	61	59	51	55	59	53	50	63	68	64	63	58	59	64	61	57	68
	6912	72	66	63	54	56	60	55	53	64	73	69	67	61	62	66	62	59	70
	13824	81	76	69	56	60	64	58	57	69	81	78	75	66	64	69	65	63	74
	17280	83	78	72	58	61	63	60	59	70	84	82	77	67	66	68	66	65	75
800x800	4608	67	63	61	51	55	61	53	51	64	71	66	65	58	59	65	61	58	69
	9216	73	67	65	54	56	61	55	54	65	75	71	69	61	62	68	62	59	72
	18432	82	76	72	57	58	65	60	59	70	83	81	76	66	65	69	65	64	75
	23040	85	81	74	58	59	66	61	59	72	86	83	78	67	66	69	66	65	76
600x600	2592	64	60	57	51	53	59	52	48	62	67	63	61	57	58	63	59	57	67
	5184	69	65	61	54	55	60	54	51	64	72	68	65	59	61	56	61	58	67
	10368	78	75	68	56	59	63	57	55	68	79	78	73	64	63	68	64	62	73
	12960	82	78	69	58	59	63	59	57	69	83	80	76	65	64	68	65	63	74



Generated noise: $D_p = 500, 1000 \text{ Pa}$

Model		$D_p = 500 \text{ Pa}$									$D_p = 1000 \text{ Pa}$								
		Sound power L_w [dB]									Sound power L_w [dB]								
B x H [mm]	Q [m³/h]	63 Hz	125 Hz	250 Hz	500 Hz	1000 Hz	2000 Hz	4000 Hz	8000 Hz	L_w A [dBA]	63 Hz	125 Hz	250 Hz	500 Hz	1000 Hz	2000 Hz	4000 Hz	8000 Hz	L_w A [dBA]
1000x400	2880	73	67	71	65	65	73	69	68	77	73	67	70	69	69	78	77	76	83
	5760	76	72	74	68	67	73	71	68	78	79	76	79	75	73	79	78	77	84
	11520	85	81	85	74	70	73	71	71	81	85	87	89	83	77	80	78	78	87
	14400	88	85	86	76	71	74	71	72	82	89	90	72	84	78	80	78	79	87
1000x600	4320	75	69	75	66	66	74	71	68	78	74	72	74	73	70	80	78	76	84
	8640	79	73	79	69	67	7	72	71	77	81	79	83	78	75	82	78	77	86
	17280	87	83	88	74	71	75	72	73	83	88	89	92	84	78	82	79	78	89
	21600	89	86	91	76	72	75	72	73	85	88	92	95	86	80	82	79	79	91
1000x800	5760	76	71	77	68	68	74	72	69	79	74	71	76	72	72	80	79	77	85
	11520	81	75	81	72	68	76	72	69	80	81	82	86	79	75	81	79	77	86
	23040	89	85	91	76	72	77	74	72	85	87	90	96	85	79	83	79	78	91
	28800	92	88	94	78	73	76	74	73	87	90	93	99	89	80	83	79	79	93
1000x1000	7200	77	72	79	69	68	76	73	69	80	75	72	79	74	72	82	79	76	86
	14400	82	75	84	73	69	76	73	71	81	81	82	89	80	76	82	80	78	88
	28800	89	87	93	77	73	77	74	74	87	89	92	97	88	80	83	80	78	92
	36000	93	89	95	80	74	77	74	74	88	92	95	700	89	81	83	80	79	691
800x200	1152	69	65	65	63	66	69	67	65	74	69	64	64	65	68	75	76	74	81
	2304	72	68	68	63	66	68	68	66	74	76	72	72	70	72	76	76	75	82
	4608	81	78	78	69	69	71	69	68	77	82	83	82	77	75	76	77	76	84
	5760	83	81	79	71	69	71	69	68	78	84	83	83	79	75	77	77	77	84
800x400	2304	72	66	69	65	66	72	69	66	76	70	66	69	68	69	77	77	74	82
	4608	76	70	74	67	67	72	70	68	77	77	76	78	74	73	78	78	77	84
	9216	84	81	84	72	70	73	71	69	80	84	86	88	82	77	79	78	77	86
	11520	86	85	86	74	71	72	71	71	81	87	89	92	83	78	79	78	77	88
800x600	3456	74	67	73	65	66	73	71	68	77	72	69	73	70	70	79	78	76	84
	6912	78	72	78	69	67	73	72	69	78	79	78	82	77	74	80	79	77	85
	13824	86	83	87	73	72	75	72	72	82	86	89	91	84	78	80	79	77	88
	17280	89	85	89	76	72	75	72	72	84	89	92	94	85	79	82	79	78	90
800x800	4608	75	69	76	67	67	73	71	68	78	73	70	74	72	72	79	79	76	84
	9216	80	73	81	69	67	75	71	68	80	79	80	84	79	74	80	79	77	86
	18432	87	84	89	75	71	76	73	72	84	86	89	94	84	78	81	79	78	89
	23040	90	88	93	76	72	75	73	72	86	89	93	96	87	79	83	79	79	91
600x600	2592	71	66	70	65	66	71	69	67	76	70	68	69	68	69	78	77	75	83
	5184	76	72	75	67	66	72	71	68	77	78	76	79	75	74	79	78	76	84
	10368	84	81	84	72	71	74	71	71	81	85	86	88	82	77	79	78	77	86
	12960	87	84	87	75	71	74	71	71	82	87	89	92	83	79	80	78	78	88

Generated noise: $D_p = 125, 250 \text{ Pa}$

Model		$D_p = 125 \text{ Pa}$										$D_p = 250 \text{ Pa}$							
B x H [mm]	Q [m³/h]	Sound power L_w [dB]										Sound power L_w [dB]							
		63 Hz	125 Hz	250 Hz	500 Hz	1000 Hz	2000 Hz	4000 Hz	8000 Hz	$L_{w,A}$ [dBA]	63 Hz	125 Hz	250 Hz	500 Hz	1000 Hz	2000 Hz	4000 Hz	8000 Hz	$L_{w,A}$ [dBA]
600x400	1728	62	58	55	50	51	56	51	46	60	65	61	59	56	57	62	58	55	66
	3456	67	63	59	53	55	58	52	49	62	69	67	63	58	59	94	58	57	95
	6912	76	73	65	56	58	61	56	54	66	78	76	69	63	63	65	62	61	71
	8640	78	76	67	56	59	62	58	55	68	81	78	73	65	64	66	64	62	73
600x200	864	58	55	51	49	52	53	48	43	58	61	58	55	55	56	59	56	53	64
	1728	63	59	55	51	53	55	49	46	59	65	63	58	57	59	61	56	54	65
	3456	72	69	62	55	57	58	54	50	64	73	72	65	61	62	63	61	58	69
	4320	75	72	64	57	58	59	56	50	65	76	75	68	63	63	64	61	58	70
600x100	432	54	53	48	48	49	51	46	40	55	58	57	52	53	54	57	53	51	61
	864	58	58	51	49	52	53	46	43	57	62	59	55	54	56	59	55	52	63
	1728	67	66	57	53	55	55	52	46	61	71	68	62	59	60	61	58	55	67
	2160	71	69	59	55	56	56	53	47	62	74	72	65	61	61	61	59	57	68
400x400	1152	59	56	53	49	50	54	49	44	58	63	59	57	55	56	60	57	55	65
	2304	64	61	57	52	54	56	51	47	61	67	64	61	57	58	62	58	56	66
	4608	72	71	64	54	57	59	54	52	64	76	74	67	62	62	63	62	60	70
	5760	76	73	66	56	58	59	56	52	66	79	76	71	64	62	65	63	61	71
400x200	576	56	53	50	49	51	52	45	42	56	59	56	52	54	56	57	54	51	62
	1152	59	58	53	49	52	53	48	44	58	63	61	57	56	57	59	56	52	64
	2304	69	68	59	54	56	56	51	48	62	72	69	64	59	61	62	59	57	68
	2880	72	70	62	56	57	57	54	49	63	75	73	66	62	62	62	61	57	69
400x100	288	51	51	46	48	50	50	44	39	55	56	54	49	52	53	55	53	49	60
	576	55	56	49	48	51	51	45	41	56	60	57	53	53	56	57	54	50	62
	1152	64	64	56	52	54	53	49	45	59	68	67	59	58	59	59	57	55	65
	1440	68	68	57	54	55	54	51	46	61	71	69	63	60	60	58	58	56	66
200x200	288	52	51	45	47	50	49	44	38	54	56	52	47	52	53	55	53	48	60
	576	56	54	49	49	51	49	46	41	55	61	56	52	53	56	57	53	50	62
	1152	65	65	55	53	55	52	49	45	59	68	66	59	57	59	60	57	53	65
	1440	68	68	57	55	56	54	52	46	61	72	68	62	60	60	60	59	55	66
200x100	144	47	48	42	47	48	47	41	36	52	53	51	44	49	52	53	51	47	58
	288	51	52	46	47	50	48	43	38	54	57	54	48	51	54	55	51	47	60
	576	60	61	51	51	53	49	58	52	61	65	63	54	56	57	57	55	52	63
	720	64	65	53	52	54	51	49	43	59	68	66	58	58	58	56	56	53	64



Generated noise: $D_p = 500, 1000 \text{ Pa}$

Model		$D_p = 500 \text{ Pa}$									$D_p = 1000 \text{ Pa}$								
		Sound power L_w [dB]									Sound power L_w [dB]								
B x H [mm]	Q [m ³ /h]	63 Hz	125 Hz	250 Hz	500 Hz	1000 Hz	2000 Hz	4000 Hz	8000 Hz	L_w A [dBA]	63 Hz	125 Hz	250 Hz	500 Hz	1000 Hz	2000 Hz	4000 Hz	8000 Hz	L_w A [dBA]
600x400	1728	69	65	67	64	65	70	68	66	75	69	64	66	66	68	76	76	74	81
	3456	73	69	71	66	66	71	69	66	76	76	74	75	72	72	77	77	76	83
	6912	82	79	81	72	69	72	69	68	79	83	84	85	80	76	79	77	77	85
	8640	85	83	82	74	69	72	69	69	79	86	87	89	82	77	78	77	77	86
600x200	864	66	63	61	61	63	67	66	63	72	68	62	60	62	66	74	75	74	80
	1728	69	66	65	63	65	68	68	64	74	74	71	69	68	70	76	75	76	81
	3456	79	76	75	67	67	70	69	67	76	82	80	79	76	74	75	76	76	83
	4320	81	81	76	69	68	69	68	68	76	84	82	81	77	74	77	77	77	84
600x100	432	63	59	55	58	62	65	64	62	70	65	57	55	58	64	72	75	73	79
	864	65	64	58	59	63	65	66	63	71	72	66	64	65	69	73	75	75	80
	1728	75	74	68	65	65	66	67	65	73	80	76	73	72	72	73	74	75	80
	2160	76	78	71	67	67	68	67	65	74	81	78	74	72	72	74	75	76	81
400x400	1152	67	63	62	62	64	68	67	65	73	68	62	62	65	67	75	75	74	80
	2304	72	67	66	64	65	68	68	66	74	75	73	71	70	72	76	76	77	82
	4608	79	78	76	70	69	70	68	68	77	83	82	81	78	75	77	76	77	84
	5760	83	81	79	72	68	70	69	68	78	85	85	84	80	76	77	76	78	85
400x200	576	64	61	57	58	62	65	65	63	71	67	59	56	60	66	73	74	74	79
	1152	67	65	61	61	63	65	67	64	72	73	68	65	67	69	74	74	76	80
	2304	77	74	71	65	67	68	68	65	74	80	79	75	73	73	74	75	77	82
	2880	79	79	72	67	66	68	68	66	75	83	80	76	74	73	76	76	77	83
400x100	288	61	58	52	56	61	63	63	61	69	63	55	50	57	63	71	73	73	78
	576	63	62	54	58	62	63	64	62	70	72	64	59	63	67	72	73	74	79
	1152	73	72	64	62	65	65	66	63	72	78	74	69	69	71	72	73	75	79
	1440	75	76	66	64	66	65	66	65	73	81	76	70	70	72	73	73	76	80
200x200	288	60	58	51	56	61	64	64	61	70	63	55	51	56	63	70	73	73	77
	576	64	61	55	58	62	63	64	62	70	71	64	60	62	67	71	73	74	78
	1152	73	71	65	62	65	66	66	63	72	78	74	69	69	72	72	74	75	80
	1440	75	76	66	65	65	66	66	64	73	80	86	70	70	72	73	74	76	81
200x100	144	57	55	46	52	58	62	62	59	67	61	52	44	53	61	68	72	72	76
	288	60	58	49	55	59	62	63	59	68	68	61	54	59	65	68	83	84	87
	576	69	69	58	59	63	62	64	62	70	76	70	63	66	69	69	72	75	78
	720	71	73	60	62	64	63	64	62	70	78	72	64	66	69	69	72	76	79

Radiated noise: $D_p = 125, 250 \text{ Pa}$

Model		$D_p = 125 \text{ Pa}$									$D_p = 250 \text{ Pa}$								
		Sound power L_w [dB]									Sound power L_w [dB]								
B x H [mm]	Q [m³/h]	63 Hz	125 Hz	250 Hz	500 Hz	1000 Hz	2000 Hz	4000 Hz	8000 Hz	$L_{w,A}$ [dBA]	63 Hz	125 Hz	250 Hz	500 Hz	1000 Hz	2000 Hz	4000 Hz	8000 Hz	$L_{w,A}$ [dBA]
1000x400	2880	54	49	41	29	27	28	23	22	38	57	54	44	33	32	36	31	31	43
	5760	63	58	48	33	31	31	26	26	45	65	63	52	38	36	37	33	34	50
	11520	72	67	54	36	33	35	31	32	53	74	72	59	44	39	41	36	37	58
	14400	75	71	56	37	35	36	31	32	57	76	75	63	45	40	41	38	39	61
1000x600	4320	57	51	42	28	29	30	22	24	40	59	55	48	36	33	37	33	32	45
	8640	66	61	49	33	31	34	27	28	48	67	65	54	39	36	39	36	35	52
	17280	75	69	57	37	34	36	32	34	55	76	74	62	44	41	42	38	39	60
	21600	78	73	58	38	35	36	33	34	59	78	76	65	47	41	42	39	41	62
1000x800	5760	58	53	43	29	29	31	25	26	41	61	56	49	37	35	38	33	33	46
	11520	67	62	51	34	31	34	28	30	49	69	65	57	42	38	40	35	36	53
	23040	76	71	57	36	35	38	32	34	57	77	76	64	46	41	42	38	39	62
	28800	79	75	59	38	36	38	34	35	60	81	77	67	48	43	43	39	41	64
1000x1000	7200	59	54	45	30	29	32	24	27	42	68	64	65	59	60	67	62	59	70
	14400	69	63	52	33	32	36	29	31	50	70	66	58	43	38	42	36	37	54
	28800	77	72	58	37	35	39	33	36	58	79	76	65	46	42	43	39	41	62
	36000	81	75	62	38	36	39	35	36	61	81	79	68	48	43	44	40	41	65
800x200	1152	48	45	35	27	26	25	18	17	34	51	48	39	33	31	32	28	27	39
	2304	57	54	42	29	28	28	22	23	41	59	56	47	36	35	33	30	31	45
	4608	66	64	49	33	32	31	26	26	49	68	66	54	42	38	36	33	34	52
	5760	69	67	51	35	33	32	28	27	52	70	69	58	42	39	38	34	35	55
800x400	2304	52	49	39	27	28	27	21	22	37	56	52	43	33	32	34	31	30	42
	4608	61	57	46	32	30	31	26	25	44	63	60	51	39	35	36	32	34	48
	9216	70	66	53	35	34	34	29	31	52	73	69	58	43	39	39	35	37	56
	11520	74	69	56	36	34	34	30	32	55	74	73	61	45	40	40	37	38	59
800x600	3456	55	49	42	27	28	29	22	23	39	57	54	46	35	34	36	31	31	44
	6912	64	59	48	33	31	32	26	27	46	65	63	53	39	37	38	34	34	50
	13824	73	68	55	36	34	35	31	32	54	74	71	61	45	41	40	37	38	58
	17280	76	71	58	36	35	36	33	34	57	76	74	64	46	41	42	38	39	61
800x800	4608	56	52	43	28	27	31	23	24	40	59	55	49	36	33	38	32	32	46
	9216	65	61	51	32	31	33	27	28	48	68	64	56	41	36	39	34	35	52
	18432	74	69	57	35	33	36	32	33	55	76	74	64	45	40	41	37	38	60
	23040	77	74	59	37	34	37	32	35	59	79	77	66	47	41	42	38	39	63
600x600	2592	53	48	39	27	27	28	20	21	37	56	52	45	34	33	35	30	30	43
	5184	62	58	47	33	29	31	25	25	45	64	61	52	38	36	37	33	33	49
	10368	71	67	54	36	33	35	29	30	53	73	70	59	44	39	39	36	37	56
	12960	74	71	55	36	34	34	32	31	56	75	73	62	45	41	40	37	38	59



Radiated noise: $D_p = 500, 1000 \text{ Pa}$

Model		$D_p = 500 \text{ Pa}$									$D_p = 1000 \text{ Pa}$								
		Sound power L_w [dB]									Sound power L_w [dB]								
B x H [mm]	Q [m ³ /h]	63 Hz	125 Hz	250 Hz	500 Hz	1000 Hz	2000 Hz	4000 Hz	8000 Hz	$L_{w,A}$ [dBA]	63 Hz	125 Hz	250 Hz	500 Hz	1000 Hz	2000 Hz	4000 Hz	8000 Hz	$L_{w,A}$ [dBA]
1000x400	2880	61	55	53	41	38	43	42	41	50	64	59	56	47	44	49	48	49	56
	5760	69	64	61	46	42	44	42	43	56	70	69	65	54	48	51	49	52	61
	11520	77	74	71	52	45	45	43	45	64	78	79	75	61	52	51	49	53	69
	14400	81	78	72	54	46	45	44	47	66	81	83	78	62	53	51	49	53	72
1000x600	4320	63	58	55	43	39	45	43	42	52	65	62	59	49	45	52	49	51	58
	8640	71	66	65	48	43	46	43	45	59	73	71	69	56	49	52	51	52	63
	17280	79	76	74	53	46	47	44	47	67	79	82	78	63	53	52	51	52	72
	21600	82	79	77	55	47	47	45	48	70	82	84	81	64	54	53	51	53	74
1000x800	5760	64	58	58	45	41	45	43	43	53	68	65	63	51	45	51	49	51	59
	11520	73	67	67	51	43	47	44	45	60	75	76	72	59	49	53	51	52	66
	23040	81	78	77	55	47	48	45	47	70	79	81	79	64	53	54	52	52	72
	28800	84	81	79	58	48	48	45	47	72	81	84	82	65	55	54	52	53	75
1000x1000	7200	65	59	61	45	42	46	43	44	55	67	65	63	53	46	52	51	50	60
	14400	74	68	69	52	44	48	45	45	62	73	75	74	59	51	53	52	51	67
	28800	82	79	78	57	47	49	45	48	71	81	85	82	65	54	55	52	53	75
	36000	85	82	81	59	48	49	46	48	74	83	88	86	67	55	54	52	53	79
800x200	1152	56	52	45	37	38	40	39	38	47	67	63	62	64	66	75	76	73	81
	2304	64	61	53	42	40	41	40	41	51	68	64	58	48	46	47	48	50	57
	4608	73	70	63	48	44	42	41	42	58	75	74	67	55	50	48	49	50	63
	5760	75	74	65	51	45	42	42	44	61	77	78	71	58	51	49	49	51	66
800x400	2304	59	53	51	41	38	42	41	40	49	63	58	54	47	44	48	49	48	55
	4608	68	63	59	45	42	43	42	42	54	69	68	64	53	47	49	49	51	60
	9216	76	74	69	52	45	44	43	44	63	76	79	74	59	52	51	49	52	68
	11520	79	77	72	53	46	44	43	47	66	79	82	76	62	5	50	49	52	70
800x600	3456	62	55	54	43	39	44	43	41	51	64	62	57	48	45	51	49	49	57
	6912	71	65	63	47	43	45	43	44	57	72	71	67	56	49	52	51	50	62
	13824	78	75	73	52	46	46	45	46	66	79	81	76	62	52	51	50	52	70
	17280	81	78	76	54	47	46	45	47	69	81	84	79	63	54	53	51	52	73
800x800	4608	63	57	57	43	41	44	42	42	52	65	62	59	49	46	51	50	50	58
	9216	72	66	66	49	42	46	43	44	59	72	73	69	56	48	52	51	52	64
	18432	81	77	75	53	45	48	44	46	68	79	82	78	62	53	52	51	53	72
	23040	83	81	78	55	47	47	45	46	71	82	84	82	65	54	53	51	53	75
600x600	2592	60	55	52	41	38	43	42	40	50	62	59	55	46	44	49	48	50	56
	5184	68	64	61	46	42	44	42	43	55	71	68	65	54	48	51	49	51	61
	10368	76	74	69	51	45	46	43	45	63	77	79	74	59	52	50	49	52	68
	12960	79	77	73	53	46	45	43	47	66	79	82	76	62	52	51	50	53	70

Radiated noise: $D_p = 125, 250 \text{ Pa}$

Model		$D_p = 125 \text{ Pa}$									$D_p = 250 \text{ Pa}$								
		Sound power L_w [dB]									Sound power L_w [dB]								
B x H [mm]	Q [m ³ /h]	63 Hz	125 Hz	250 Hz	500 Hz	1000 Hz	2000 Hz	4000 Hz	8000 Hz	L_w A [dBA]	63 Hz	125 Hz	250 Hz	500 Hz	1000 Hz	2000 Hz	4000 Hz	8000 Hz	L_w A [dBA]
600x400	1728	50	48	37	27	26	27	20	20	36	54	50	41	33	31	33	29	29	41
	3456	59	56	44	32	29	29	25	23	43	62	59	49	38	34	35	31	32	47
	6912	68	66	51	34	33	32	28	28	51	71	68	57	42	38	38	34	35	55
	8640	71	68	52	36	33	34	29	29	53	73	72	59	45	39	39	35	37	58
600x200	864	46	44	33	26	25	24	18	16	33	51	47	38	32	30	31	27	26	38
	1728	55	53	40	29	28	26	21	20	39	58	55	45	35	33	32	29	29	43
	3456	64	62	48	33	32	29	25	24	48	67	65	53	41	37	35	32	33	51
	4320	67	65	49	36	32	31	27	25	50	69	68	5	42	38	36	33	35	53
600x100	432	41	41	31	25	23	21	16	<15	30	47	45	33	29	28	28	26	24	36
	864	50	51	37	28	26	25	18	17	37	55	53	41	33	31	30	27	28	41
	1728	59	58	44	32	29	27	23	22	44	63	61	48	38	36	32	30	31	47
	2160	63	62	46	33	31	27	25	22	47	66	65	51	39	36	33	31	32	51
400x400	1152	47	45	36	26	25	25	17	17	34	52	48	39	31	30	31	29	28	39
	2304	56	55	42	31	28	27	22	21	41	60	58	46	36	33	33	31	31	45
	4608	65	63	49	34	31	30	26	26	49	69	67	53	41	37	36	33	35	53
	5760	68	66	52	34	32	32	27	27	51	72	70	56	44	38	37	34	36	56
400x200	576	43	42	31	26	24	22	16	<15	31	48	46	34	30	29	29	27	25	37
	1152	52	50	38	29	26	24	19	18	37	56	53	41	35	32	31	28	28	41
	2304	61	60	46	32	31	27	23	22	46	65	63	49	39	37	33	32	33	49
	2880	64	63	48	34	31	28	26	23	48	67	66	53	40	37	35	32	33	52
400x100	288	38	39	28	24	22	19	<15	<15	29	45	42	31	28	27	26	25	23	34
	576	47	48	36	28	26	22	16	15	35	53	50	37	33	31	28	26	26	39
	1152	56	56	41	32	28	24	22	19	42	62	59	45	37	35	31	29	30	46
	1440	61	60	43	32	29	26	22	21	45	64	63	48	38	35	31	30	32	49
200x200	288	39	39	28	25	23	20	<15	<15	29	46	42	30	27	27	28	24	22	34
	576	48	47	34	28	26	21	17	15	34	53	49	37	32	30	28	26	25	38
	1152	57	57	42	31	29	25	22	19	42	62	59	46	36	35	32	29	29	46
	1440	61	60	44	33	31	25	24	21	45	64	62	48	38	35	33	30	30	48
200x100	144	35	36	25	23	22	16	<15	<15	27	42	38	27	25	26	25	23	21	32
	288	43	45	32	26	25	19	<15	<15	32	51	46	34	29	28	26	24	23	36
	576	52	53	37	31	27	22	19	16	39	58	55	42	34	32	28	27	27	42
	720	56	57	39	32	28	23	21	17	42	61	59	43	35	33	29	29	28	45



Radiated noise: $D_p = 500, 1000 \text{ Pa}$

Model		$D_p = 500 \text{ Pa}$										$D_p = 1000 \text{ Pa}$							
		Sound power L_w [dB]										Sound power L_w [dB]							
B x H [mm]	Q [m ³ /h]	63 Hz	125 Hz	250 Hz	500 Hz	1000 Hz	2000 Hz	4000 Hz	8000 Hz	L_w A [dBA]	63 Hz	125 Hz	250 Hz	500 Hz	1000 Hz	2000 Hz	4000 Hz	8000 Hz	L_w A [dBA]
600x400	1728	57	53	47	39	38	41	40	39	48	62	56	52	45	43	47	48	48	54
	3456	66	63	56	44	41	42	41	41	53	69	67	61	50	46	49	48	50	58
	6912	74	73	66	51	44	43	42	43	61	76	77	71	57	51	49	48	52	66
	8640	77	76	68	52	45	44	42	45	63	79	79	73	59	52	49	49	52	68
600x200	864	54	51	42	36	36	39	38	38	45	59	54	46	41	40	45	47	48	53
	1728	62	59	51	41	39	41	39	39	49	67	62	54	47	45	46	46	50	55
	3456	71	69	61	47	43	41	40	41	57	74	72	65	53	48	46	48	51	61
	4320	73	73	63	49	43	41	41	43	60	77	76	67	55	50	48	47	51	64
600x100	432	51	48	36	34	35	37	36	35	43	58	51	41	38	38	43	45	48	51
	864	58	56	44	39	37	37	38	37	46	65	59	48	43	42	44	46	49	53
	1728	67	66	54	44	41	38	38	39	53	72	69	58	49	47	44	46	49	57
	2160	69	71	56	45	42	39	39	40	56	75	72	61	51	48	46	45	51	60
400x400	1152	55	51	43	38	36	39	39	38	46	61	55	48	42	41	47	46	49	53
	2304	64	61	52	42	39	41	40	40	50	68	65	57	48	45	47	48	50	57
	4608	72	71	62	48	44	42	41	42	58	75	74	67	55	49	48	48	52	63
	5760	75	74	64	51	44	42	41	44	61	78	77	69	57	51	48	47	52	65
400x200	576	52	49	39	34	35	37	37	36	44	59	52	41	38	39	45	46	48	52
	1152	61	58	46	39	39	38	38	38	48	65	61	51	44	43	46	45	49	54
	2304	69	67	56	46	42	39	39	41	54	72	71	61	52	47	46	47	50	59
	2880	72	71	58	48	43	39	40	41	57	76	74	64	53	48	47	46	51	62
400x100	288	49	46	33	31	33	35	36	34	42	57	48	36	35	37	41	44	48	50
	576	56	54	41	36	36	35	36	36	44	64	56	45	42	41	43	44	48	52
	1152	65	64	51	41	39	36	37	39	51	71	66	55	48	46	43	44	50	56
	1440	67	68	53	43	41	37	38	39	54	74	70	57	49	47	45	45	51	58
200x200	288	48	46	32	31	33	35	35	34	41	55	49	36	35	38	42	44	48	51
	576	56	54	41	36	36	37	36	36	45	62	57	45	41	42	43	45	49	52
	1152	65	64	51	42	39	37	37	38	51	69	67	54	47	46	42	46	49	56
	1440	67	68	52	45	41	37	38	39	54	73	69	58	49	47	43	46	49	57
200x100	144	45	42	27	28	32	33	34	32	40	54	45	31	32	36	38	44	47	49
	288	52	51	34	33	34	33	35	34	42	60	53	38	37	40	39	43	48	50
	576	61	61	45	38	37	34	35	36	48	67	63	48	44	43	41	44	49	53
	720	63	65	46	41	38	35	36	38	51	71	66	52	46	45	42	43	50	55

Variable air volume flow controllers



LMV-D3-MP



NMV-D3-MP

VAV-Compact controller with integrated pressure sensor, VAV controller and damper actuator for pressure-independent VAV and CAV applications in the comfort zone

- Control: DC 0/2 ... 10V / MP-Bus
- Integration in bus systems
 - DDC controller with MP interface
 - LONWORKS® systems
 - Fan optimiser systems
- With additional switch-on option for sensors and switches
- Diagnostic socket for Service and PC-Tool

Type overview

Type	Torque	Power consumption	Dimensioning	Weight
LMV-D3-MP	5 Nm	2 W	4 VA (max. 8 A @ 5 ms)	Approx. 500 g
NMV-D3-MP	10 Nm	3 W	5 VA (max. 8 A @ 5 ms)	Approx. 700 g

Brief description

Application	The digital VAV-Compact has PI control characteristics and is used for pressure-independent control of VAV units in the comfort zone.
Pressure measurement	The integrated maintenance-free Belimo D3 differential pressure sensor is also suitable for very small volumetric flows. It is for this reason that it covers versatile applications in the comfort zone, e.g. in residential construction, offices, hospitals, hotels, cruise ships, etc.
Actuator	Three versions available, depending on the size of the VAV unit: 5 / 10 / 20 Nm. – Rotary actuator, depending on the size – Linear actuator 150 N with 100, 200 or 300 mm linear movement.
Control function	VAV-CAV or Open-Loop operation for integration in an external VAV control loop.
Feedback	Damper position for fan optimiser systems, current volumetric flow or pressure value.
VAV – variable volumetric flow	For variable volumetric flow applications with a modulating reference variable, e.g. room temperature controller, direct digital control or bus system, it enables demand-related, energy-saving ventilation of individual rooms or zones. The operating range $V_{\min} \dots V_{\max}$ can be connected via selectable mode. The following are available: DC 2 ... 10V / 0 ... 10V / adjustable range / bus operation.
CAV – constant volumetric flow	For constant volumetric flow applications, e.g. in step mode, controlled by means of a switch. The following operating modes can be selected from: CLOSED / V_{\min} / (V_{mid}) / V_{\max} / OPEN
Bus function	Up to eight Belimo MP devices (VAV / damper actuator / valve actuator) can be connected together over the MP-Bus and integrated into the following systems: – LONWORKS® applications with Belimo UK24LON interface – EIB Konnex applications with Belimo UK24EIB interface – MODBUS RTU applications with Belimo UK24MOD interface – BACnet applications with Belimo UK24BAC interface – DDC controller with integrated MP-Bus protocol – Fan optimiser applications with optimiser COU24-A-MP A sensor (0...10V or passive), e.g. a temperature sensor or a switch, can optionally be integrated into the higher-level DDC or bus system via the MP-Bus.
Operating and service devices	Belimo PC-Tool or service tool ZTH-GEN, can be plugged into the VAV-Compact (PP connection) or via MP-Bus.
Assembly and connection	The VAV-Compact, which is assembled on the unit by the OEM, is connected using the prefabricated connecting cable.
Test function / test display	The VAV-Compact features two LEDs with a functional readiness display for commissioning and functional checking. Extended information with ZTH-GEN.
OEM factory settings	The VAV-Compact is mounted on the VAV unit by the unit manufacturer, who adjusts and tests it according to the application. The VAV-Compact is sold exclusively via the OEM channel for this reason.

Variable air volume flow controllers

Technical data

Safety	
Principle of operation	Type 1 (in acc. with EN 60730-1)
Rated current voltage	0.5 kV (in accordance with EN 60730-1)
Control pollution degree	2 (in accordance with EN 60730-1)
Ambient temperature	0 ... +50 °C
Non-operating temperature	-20 ... +80 °C
Ambient humidity	5 ... 95% r.h., non-condensing (in accordance with EN 60730-1)
Maintenance	Maintenance-free

Connection

Notes

- Supply via safety isolating transformer! 
- In conventionally controlled systems it is recommended that the connections 1 to 5 (PP) are led to accessible terminals (e.g. floor distributor) in order to allow remote access for diagnostics and service work.

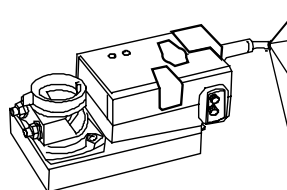

Nr.	Designation	Wire	Function
1	-	Black	Supply AC/DC 24 V
2	~ +	Red	
3	Y	White	Reference signal / override / sensor
5	U	Orange	- Actual value signal - MP bus connection

VAV – variable operation $V_{min} \dots V_{max}$

Wiring diagrams

Example 1: VAV, analogue reference signal

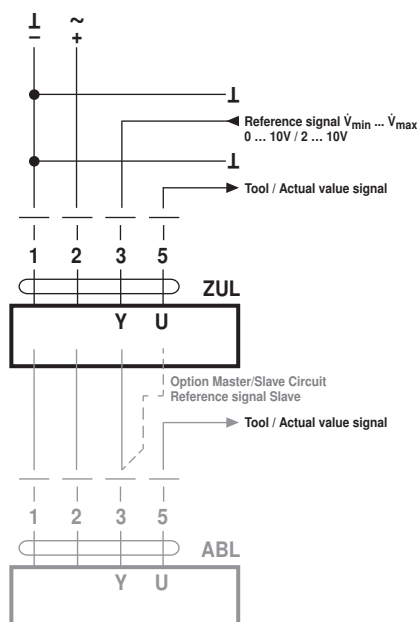

Example 2: VAV with shut-off (CLOSED), 2 ... 10V mode

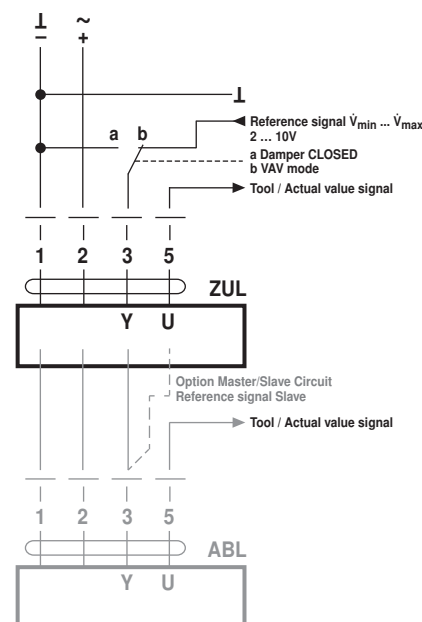

Description:

Damper CLOSED via 0 ... 10 V reference signal (Mode 2 ... 10 V)

Setting parameters:
Mode 2 ... 10 V, Shut off level 0.1 V or 0.5 V

If the required switching threshold of 0.1 V cannot be attained, the value can be switched to 0.5 V with PC-Tool.

Function: Standard 0.1 V: Shut-off level 0.5 V:

Damper		
CLOSED	<0.1 V	<0.5 V
V_{min}	>0.1 ... 2 V	>0.5 V ... 2 V
$V_{min} \dots V_{max}$	2 ... 10 V	2 ... 10 V

In CAV applications shut-off level must not be set to 0.5 V, otherwise the open connection 3 is interpreted as damper CLOSED.

CAV – step mode CLOSED / V_{min} / V_{mid} / V_{max} / OPEN

- CAV control** VAV-Compact can be adapted to the desired CAV function pattern for constant volumetric flow applications with PC-Tool by using the "CAV function":
- Damper CLOSED – V_{min} – V_{max} – damper OPEN (standard)
 - Damper CLOSED – V_{min} – V_{mid} – V_{max} – damper OPEN (NMV-D2M compatible)

Wiring diagrams

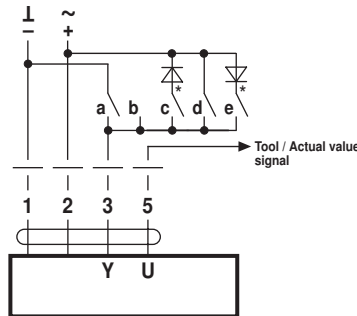

Notes

- Note that the contacts are mutually interlocking.
- DC supply: * c and e are not available with DC 24 V.
- Setting parameters in CAV applications:
Mode 2 ... 10 V, Shut-off level 0.1 V
In CAV applications shut-off level must not be set to 0.5 V, otherwise the open connection 3 is interpreted as damper CLOSED.

PC-Tool "CAV Function" setting:
2 ... 10 V, Shut-off level 0.1 V

CAV Function CLOSED – V_{min} – V_{max} – OPEN (standard)

	a	b	c	d	e
Signal	\perp –		\sim	\sim +	\sim
Switching terminal 3	$\frac{ }{3}$	$\frac{ }{3}$	$\frac{\text{N}}{3}$	$\frac{ }{3}$	$\frac{\text{N}}{3}$
Mode 2 ... 10 V	CLOSED	V_{min}	CLOSED *	V_{max}	OPEN *
Mode 0 ... 10 V	V_{min}	V_{min}	CLOSED *	V_{max}	OPEN *

PC-Tool "CAV Function" setting:
CLOSED – V_{min} – V_{max} . Shut-off level CLOSED: 0.1 V

CAV function CLOSED – V_{min} – V_{mid} – V_{max} – OPEN

	a	b	c	d	e
Signal	\perp –		\sim	\sim +	\sim
Switching terminal 3	$\frac{ }{3}$	$\frac{ }{3}$	$\frac{\text{N}}{3}$	$\frac{ }{3}$	$\frac{\text{N}}{3}$
Mode 2 ... 10 V	CLOSED	V_{min}	V_{mid} *	V_{max}	OPEN *
Mode 0 ... 10 V	V_{min}	V_{min}	V_{mid} *	V_{max}	OPEN *

PC-Tool "CAV Function" setting:
CLOSED – V_{min} – V_{mid} – V_{max} (NMV-D2M compatible)

MP-Bus operation – VAV / CAV function

Connection on the MP-Bus

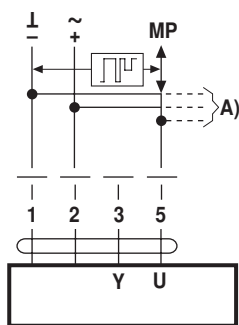

A) Additional actuators and sensors (max. 8)

Power topology

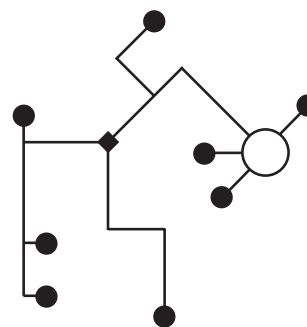

There are no restrictions for the network topology (star, ring, tree or mixed forms are permitted).
Supply and communication in one and the same 3-wire cable

- no shielding or twisting necessary
- no terminating resistors required

Connection of active sensors

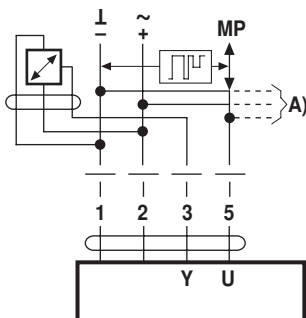

A) Additional actuators and sensors (max. 8)

- Supply AC/DC 24 V
- Output signal DC 0...10 V (max. DC 0...32 V)
- Resolution 30 mV

Connection of external switching contact

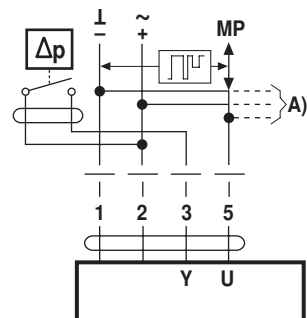

A) Additional actuators and sensors (max. 8)

- Switching current 16 mA @ 24 V
- Start point of the operating range must be parameterised on the MP actuator as ≥ 0.5 V

MP-Bus operation – VAV / CAV function

Connection of passive sensors

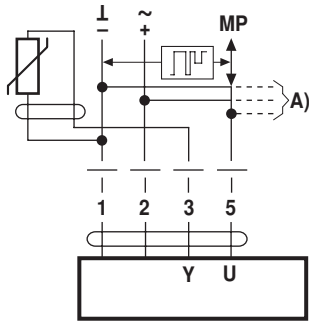

Ni1000	-28...+98 °C	850...1600 Ω ²⁾
PT1000	-35...+155 °C	850...1600 Ω ²⁾
NTC	-10...+160 °C ¹⁾	200 Ω...60 kΩ ²⁾

A) Additional actuators and sensors (max. 8)

1) Depending on the type
2) Resolution 1 Ohm

Local override control

If no sensor is integrated, then connection 3 (Y) is available for the protective circuit of a local override control.

Options: CLOSED – \dot{V}_{max} – OPEN

Note: Functions only with AC 24V supply!

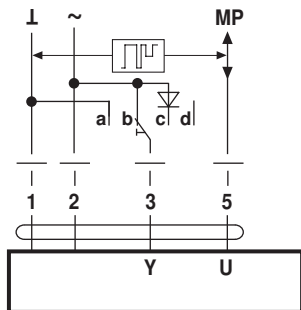

- a Damper CLOSED
- b \dot{V}_{Max}
- c Damper OPEN
- d Bus mode

Dimensioning of supply and connecting cable

General In addition to the actual wire sizing, attention must also be paid to the surrounding environment and the cable routing. If at all possible, signal cables must not be laid in the vicinity of load cables, objects liable to cause EMC interference, etc. Paired or layer-stranded cables enhance interference resistance.

24 V supply, dimensioning and cabling

The wire sizing and installation of the 24V AC supply, the fuse protection and the cables are dependent on the total operated load and local regulations. Account must be taken of the following performance data, including the starting currents of the actuators:

- Dimensioning values VAV-Compact controller, see Technical data
- Dimensioning values of other final controlling elements, etc. can be found in the current data sheets and product information
- Additional intended devices which are connected to the same 24V supply
- Reserve capacity for subsequent expansion, if planned.

MP-Bus integration – supply, dimensioning and cabling

See S4-VAV-Compact D3, MP-Bus integration, page 33 ... 42