

Constant volume flow regulator MRP-5



Description

Regulator versions: **MRP-5** – Constant volume flow regulator, circular **MRP-5-I** – Constant volume flow regulator, circular – insulated

Technical data

Construction The damper blades shaft is supported by two smooth-running maintenance-free brass bearings. Pneumatic shock absorber smooths out the damping shock impulse, preventing the vibration and oscillation of the damper blade to ensure sensitive responding behaviour and a precise control.

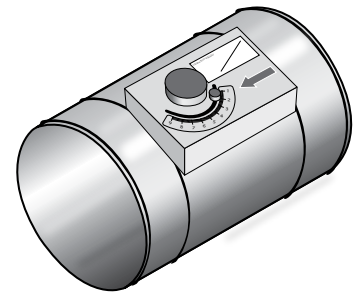
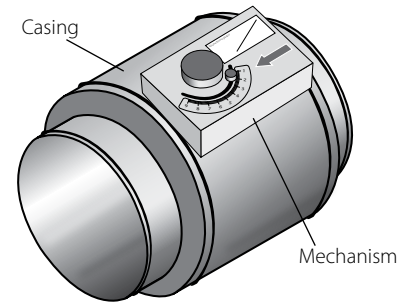

CASING – made of galvanised sheet steel

MECHANISM – control lever mechanism adjusts the spring tension to control the air flow

DAMPER BLADE – provides resistance to the air flow

SHOCK ABSORBER – serves to absorb the damper blade vibration caused by the air flow

INSULATION CLADDING – 30 mm mineral wool layer with galvanised sheet steel outer

Quick selection table

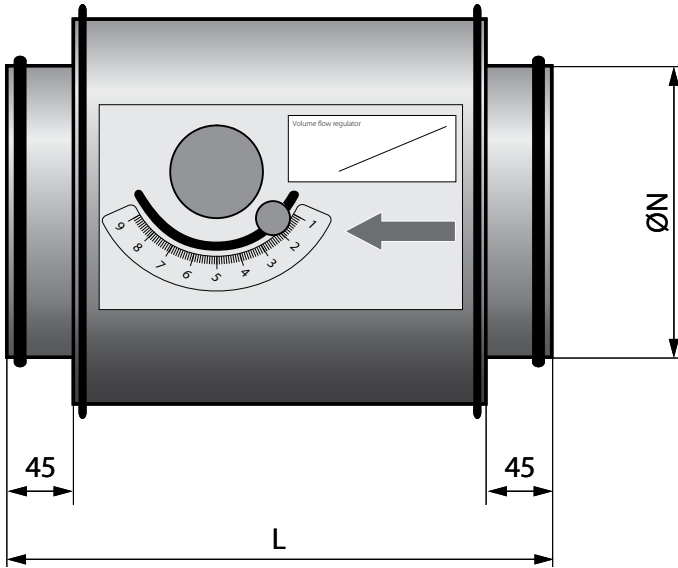

Size (ØN) [mm]	Length (L) [mm]
80	300
100	300
125	300
160	300
200	300
250	400
315	400
355	400
400	400

Dimensions

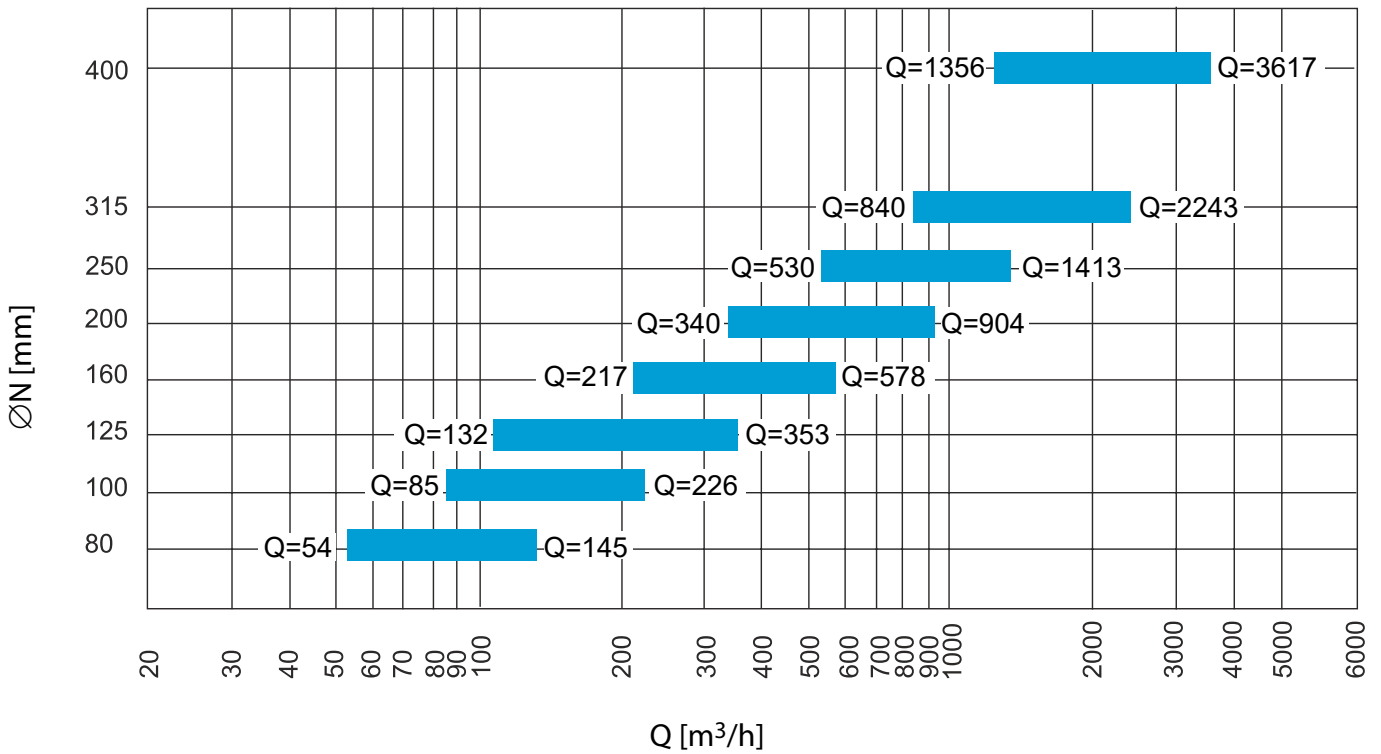

Flow rate range in relation to duct cross section

* Flow rate calibration possible at air velocities from 3 to 8 m/s.

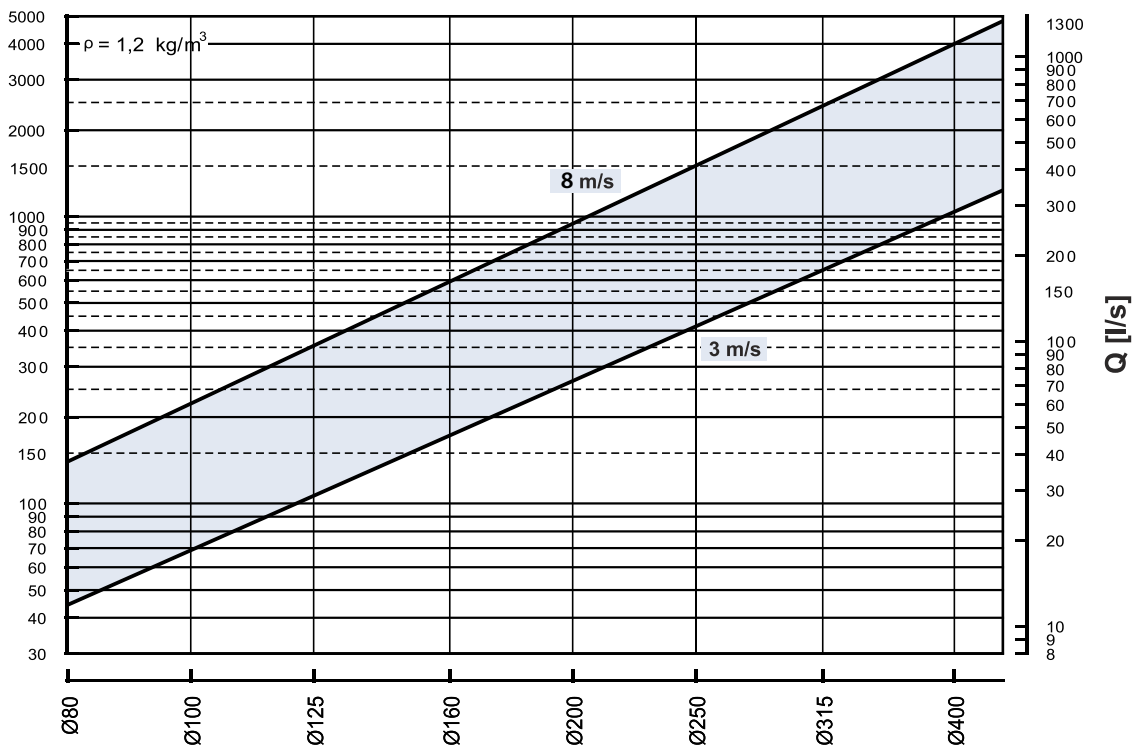

Minimum static pressure difference at the regulator.

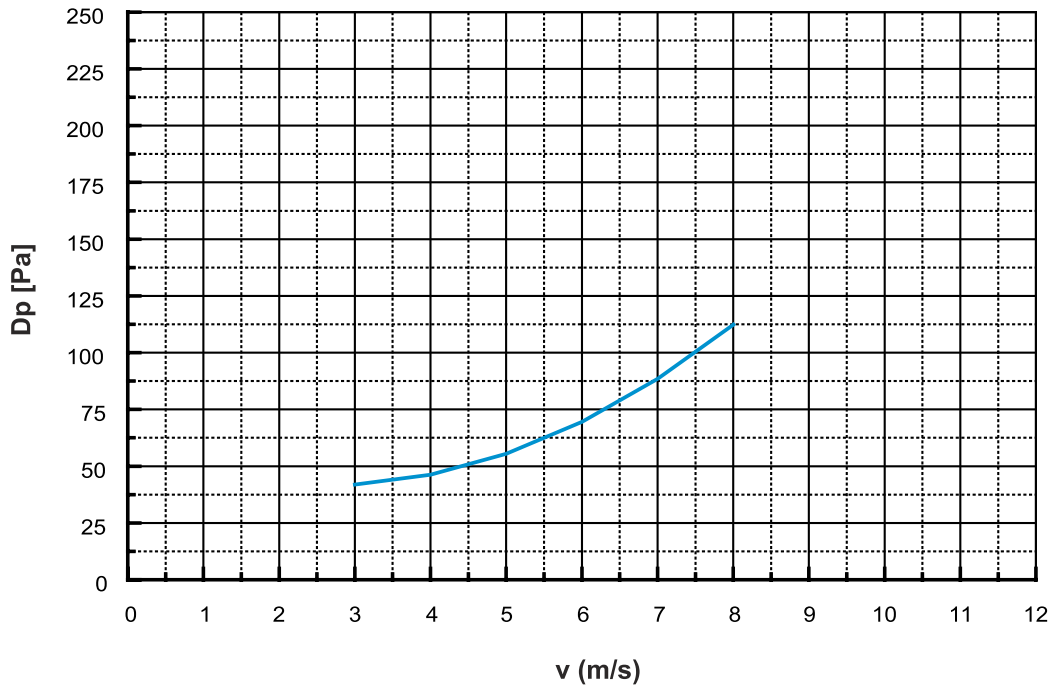

Legend:

Q [m³/h or l/s]	flow rate
v [m/s]	air velocity
A [m²]	effective outlet area
D_p [Pa]	static pressure difference

Generated noise MRP-5

Modell		$D_p = 125 \text{ Pa}$									$D_p = 250 \text{ Pa}$									$D_p = 500 \text{ Pa}$								
		Sound power L_w [dB]									Sound power L_w [dB]									Sound power L_w [dB]								
\varnothing [mm]	Q [m ³ /h]	63 Hz	125 Hz	250 Hz	500 Hz	1000 Hz	2000 Hz	4000 Hz	8000 Hz	$L_w A$ [dBA]	63 Hz	125 Hz	250 Hz	500 Hz	1000 Hz	2000 Hz	4000 Hz	8000 Hz	$L_w A$ [dBA]	63 Hz	125 Hz	250 Hz	500 Hz	1000 Hz	2000 Hz	4000 Hz	8000 Hz	$L_w A$ [dBA]
80	54	64	53	45	41	39	39	35	30	46	60	54	48	45	42	42	40	37	49	60	57	51	49	46	47	47	45	54
	90	61	57	51	44	40	42	39	36	49	60	59	54	50	45	45	44	42	53	63	62	56	54	49	48	49	48	57
	145	59	61	59	50	45	46	44	41	55	61	64	62	56	50	48	49	47	59	63	66	62	59	53	51	52	51	61
100	85	67	51	45	41	35	30	23	19	45	65	53	49	46	43	40	35	29	49	73	67	65	62	57	53	49	49	64
	141	63	56	50	46	41	35	29	23	48	66	58	55	51	46	42	38	34	53	70	62	59	56	51	47	47	46	58
	226	63	61	55	51	46	42	35	29	53	69	65	62	57	53	48	43	39	59	73	67	65	62	57	53	49	49	64
125	132	58	53	46	43	39	32	25	21	45	62	57	52	49	46	43	38	32	52	62	61	57	54	49	50	50	46	58
	221	60	60	53	49	43	37	32	28	51	62	63	59	55	50	45	41	39	57	65	66	63	60	54	52	50	49	62
	353	63	66	58	54	50	44	40	37	57	65	70	64	60	55	50	46	44	62	68	72	69	65	60	56	53	52	67
160	217	60	56	48	46	42	42	32	28	49	63	59	53	51	48	49	41	34	55	63	61	56	54	51	53	52	46	59
	362	63	61	54	50	45	45	37	30	53	69	66	60	56	51	53	46	38	59	70	68	64	61	57	60	54	49	65
	579	66	64	57	53	50	49	43	35	57	72	70	64	61	55	57	50	43	64	74	72	70	66	61	64	57	52	70
200	339	60	52	43	43	42	41	39	32	48	64	55	48	49	49	50	48	41	56	63	57	52	52	55	56	55	50	62
	565	63	56	49	46	45	45	43	39	52	65	61	54	51	51	51	51	46	58	69	64	60	56	57	57	57	52	64
	904	68	62	53	51	50	51	48	43	57	70	67	59	56	54	54	54	48	61	74	71	64	60	59	59	59	54	66
250	530	49	46	45	45	43	43	39	32	49	55	55	52	51	51	52	48	43	57	66	58	55	55	57	59	56	53	64
	883	61	54	49	47	45	47	43	36	52	63	61	55	52	52	54	51	46	59	68	65	62	57	57	60	57	54	65
	1413	68	61	53	52	49	52	48	42	57	71	68	58	56	53	56	53	48	62	73	72	64	61	59	62	59	56	67
315	841	54	50	45	44	44	44	39	31	49	57	54	50	49	50	52	47	41	56	63	58	54	54	55	57	57	52	63
	1402	58	56	51	48	47	49	44	37	54	64	60	55	52	52	54	52	47	59	68	65	61	57	57	59	58	55	65
	2243	66	60	55	53	50	52	49	43	58	72	65	60	57	55	58	56	51	64	75	70	65	62	60	62	61	58	68
400	1356	54	54	48	50	54	54	46	39	58	59	58	53	54	59	60	54	47	64	61	61	60	60	64	67	62	56	71
	2261	62	58	54	54	57	58	51	45	62	67	63	59	57	61	63	58	51	67	70	66	63	62	66	69	65	59	73
	3617	68	63	58	57	59	61	56	50	65	73	67	63	61	64	66	62	55	70	76	71	66	65	68	71	67	62	75

Radiated noise MRP-5

Modell		$D_p = 125 \text{ Pa}$										$D_p = 250 \text{ Pa}$										$D_p = 500 \text{ Pa}$									
Ø [mm]	Q [m³/h]	Sound power L_w [dB]										Sound power L_w [dB]										Sound power L_w [dB]									
		63 Hz	125 Hz	250 Hz	500 Hz	1000 Hz	2000 Hz	4000 Hz	8000 Hz	L_w A [dBA]	63 Hz	125 Hz	250 Hz	500 Hz	1000 Hz	2000 Hz	4000 Hz	8000 Hz	L_w A [dBA]	63 Hz	125 Hz	250 Hz	500 Hz	1000 Hz	2000 Hz	4000 Hz	8000 Hz	L_w A [dBA]			
80	54	27	19	<15	19	21	27	23	20	31	23	20	15	23	24	30	28	27	35	23	23	18	27	28	35	35	35	41			
	90	24	23	18	22	22	30	27	26	34	23	25	21	28	27	33	32	32	38	26	28	23	32	31	36	37	38	43			
	145	22	27	26	28	27	34	32	31	39	24	30	29	34	32	36	37	37	43	26	32	29	37	35	39	40	41	46			
100	85	32	19	<15	20	18	18	<15	<15	24	30	21	18	25	26	28	23	19	32	33	26	24	31	31	34	35	34	40			
	141	28	24	19	25	24	23	17	<15	29	31	26	24	30	29	30	26	24	35	35	30	28	35	34	35	35	36	42			
	226	28	29	24	30	29	30	23	19	35	34	33	31	36	36	36	31	29	41	38	35	34	41	40	41	37	39	47			
125	132	32	23	16	19	17	<15	<15	<15	23	36	27	22	25	24	23	22	20	30	36	31	27	30	27	30	34	34	39			
	221	34	30	23	25	21	17	16	16	27	36	33	29	31	28	25	25	27	34	39	36	33	36	32	32	34	37	41			
	353	37	36	28	30	28	24	24	25	33	39	40	34	36	33	30	30	32	39	42	42	39	41	38	36	37	40	45			
160	217	35	33	28	28	32	33	23	24	37	38	36	33	33	38	40	32	30	44	38	38	36	36	41	44	43	42	49			
	362	38	38	34	32	35	36	28	26	40	44	43	40	38	41	44	37	34	48	45	45	44	43	47	51	45	45	55			
	579	41	41	37	35	40	40	34	31	45	47	47	44	43	45	48	41	39	52	49	49	50	48	51	55	48	48	59			
200	339	39	35	28	28	28	30	30	23	36	43	38	33	34	35	39	39	32	44	42	40	37	37	41	45	46	41	51			
	565	42	39	34	31	31	34	34	30	40	44	44	39	36	37	40	42	37	47	48	47	45	41	43	46	48	43	53			
	904	47	45	38	36	36	40	39	34	45	49	50	44	41	40	43	45	39	50	53	54	49	45	45	48	50	45	55			
250	530	30	31	31	31	30	32	30	23	37	36	40	38	37	38	41	39	34	46	47	43	41	41	44	48	47	44	53			
	883	42	39	35	33	32	36	34	27	41	44	46	41	38	39	43	42	37	48	49	50	48	43	44	49	48	45	54			
	1413	49	46	39	38	36	41	39	33	46	52	53	44	42	40	45	44	39	50	54	57	50	47	46	51	50	47	56			
315	841	37	36	32	30	31	33	30	22	38	40	40	37	35	37	41	38	32	45	46	44	41	40	42	46	48	43	52			
	1402	41	42	38	34	34	38	35	28	43	47	46	42	38	39	43	43	38	48	51	51	48	43	44	48	49	46	54			
	2243	49	46	42	39	37	41	40	34	46	55	51	47	43	42	47	47	42	52	58	56	52	48	47	51	52	49	57			
400	1356	37	38	39	43	48	50	40	24	53	42	42	44	47	53	56	48	32	59	44	45	51	53	58	63	56	41	66			
	2261	45	42	45	47	51	54	45	30	57	50	47	50	50	55	59	52	36	62	53	50	54	55	60	65	59	44	68			
	3617	51	47	49	50	53	57	50	35	60	56	51	54	54	58	62	56	40	65	59	55	57	58	62	67	61	47	70			

Generated noise MRP-5-I

Modell		$D_p = 125 \text{ Pa}$									$D_p = 250 \text{ Pa}$									$D_p = 500 \text{ Pa}$								
		Sound power L_w [dB]									Sound power L_w [dB]									Sound power L_w [dB]								
\varnothing [mm]	Q [m ³ /h]	63 Hz	125 Hz	250 Hz	500 Hz	1000 Hz	2000 Hz	4000 Hz	8000 Hz	L_w A [dBA]	63 Hz	125 Hz	250 Hz	500 Hz	1000 Hz	2000 Hz	4000 Hz	8000 Hz	L_w A [dBA]	63 Hz	125 Hz	250 Hz	500 Hz	1000 Hz	2000 Hz	4000 Hz	8000 Hz	L_w A [dBA]
80	54	64	53	45	41	39	39	35	30	46	60	54	48	45	42	42	40	37	49	60	57	51	49	46	47	47	45	54
	90	61	57	51	44	40	42	39	36	49	60	59	54	50	45	45	44	42	53	63	62	56	54	49	48	49	48	57
	145	59	61	59	50	45	46	44	41	55	61	64	62	56	50	48	49	47	59	63	66	62	59	53	51	52	51	61
100	85	67	51	45	41	35	30	23	19	45	65	53	49	46	43	40	35	29	49	73	67	65	62	57	53	49	49	64
	141	63	56	50	46	41	35	29	23	48	66	58	55	51	46	42	38	34	53	70	62	59	56	51	47	47	46	58
	226	63	61	55	51	46	42	35	29	53	69	65	62	57	53	48	43	39	59	73	67	65	62	57	53	49	49	64
125	132	58	53	46	43	39	32	25	21	45	62	57	52	49	46	43	38	32	52	62	61	57	54	49	50	50	46	58
	221	60	60	53	49	43	37	32	28	51	62	63	59	55	50	45	41	39	57	65	66	63	60	54	52	50	49	62
	353	63	66	58	54	50	44	40	37	57	65	70	64	60	55	50	46	44	62	68	72	69	65	60	56	53	52	67
160	217	60	56	48	46	42	42	32	28	49	63	59	53	51	48	49	41	34	55	63	61	56	54	51	53	52	46	59
	362	63	61	54	50	45	45	37	30	53	69	66	60	56	51	53	46	38	59	70	68	64	61	57	60	54	49	65
	579	66	64	57	53	50	49	43	35	57	72	70	64	61	55	57	50	43	64	74	72	70	66	61	64	57	52	70
200	339	60	52	43	43	42	41	39	32	48	64	55	48	49	49	50	48	41	56	63	57	52	52	55	56	55	50	62
	565	63	56	49	46	45	45	43	39	52	65	61	54	51	51	51	51	46	58	69	64	60	56	57	57	57	52	64
	904	68	62	53	51	50	51	48	43	57	70	67	59	56	54	54	54	48	61	74	71	64	60	59	59	59	54	66
250	530	49	46	45	45	43	43	39	32	49	55	55	52	51	51	52	48	43	57	66	58	55	55	57	59	56	53	64
	883	61	54	49	47	45	47	43	36	52	63	61	55	52	52	54	51	46	59	68	65	62	57	57	60	57	54	65
	1413	68	61	53	52	49	52	48	42	57	71	68	58	56	53	56	53	48	62	73	72	64	61	59	62	59	56	67
315	841	54	50	45	44	44	44	39	31	49	57	54	50	49	50	52	47	41	56	63	58	54	54	55	57	57	52	63
	1402	58	56	51	48	47	49	44	37	54	64	60	55	52	52	54	52	47	59	68	65	61	57	57	59	58	55	65
	2243	66	60	55	53	50	52	49	43	58	72	65	60	57	55	58	56	51	64	75	70	65	62	60	62	61	58	68
400	1356	54	54	48	50	54	54	46	39	58	59	58	53	54	59	60	54	47	64	61	61	60	60	64	67	62	56	71
	2261	62	58	54	54	57	58	51	45	62	67	63	59	57	61	63	58	51	67	70	66	63	62	66	69	65	59	73
	3617	68	63	58	57	59	61	56	50	65	73	67	63	61	64	66	62	55	70	76	71	66	65	68	71	67	62	75

Radiated noise MRP-5-I

Modell		$D_p = 125 \text{ Pa}$										$D_p = 250 \text{ Pa}$										$D_p = 500 \text{ Pa}$									
Ø [mm]	Q [m³/h]	Sound power L_w [dB]										Sound power L_w [dB]										Sound power L_w [dB]									
		63 Hz	125 Hz	250 Hz	500 Hz	1000 Hz	2000 Hz	4000 Hz	8000 Hz	L_w A [dBA]	63 Hz	125 Hz	250 Hz	500 Hz	1000 Hz	2000 Hz	4000 Hz	8000 Hz	L_w A [dBA]	63 Hz	125 Hz	250 Hz	500 Hz	1000 Hz	2000 Hz	4000 Hz	8000 Hz	L_w A [dBA]			
80	54	20	<15	<15	<15	<15	<15	<15	<15	22	16	15	<15	<15	<15	<15	<15	<15	22	16	18	<15	<15	<15	<15	<15	<15	<15	22		
	90	17	18	<15	<15	<15	<15	<15	<15	22	16	20	<15	<15	<15	<15	<15	<15	22	19	23	<15	<15	<15	<15	<15	<15	22			
	145	15	22	<15	<15	<15	<15	<15	<15	22	17	25	15	<15	<15	<15	<15	<15	22	19	27	15	<15	<15	<15	<15	<15	22			
100	85	25	<15	<15	<15	<15	<15	<15	<15	22	23	16	<15	<15	<15	<15	<15	<15	22	26	21	<15	<15	<15	<15	<15	<15	22			
	141	21	19	<15	<15	<15	<15	<15	<15	22	24	21	<15	<15	<15	<15	<15	<15	22	28	25	<15	<15	<15	<15	<15	<15	22			
	226	21	24	<15	<15	<15	<15	<15	<15	22	27	28	17	<15	<15	<15	<15	<15	22	31	30	20	16	<15	<15	<15	<15	23			
125	132	25	18	<15	<15	<15	<15	<15	<15	22	29	22	<15	<15	<15	<15	<15	<15	22	29	26	<15	<15	<15	<15	<15	<15	22			
	221	27	25	<15	<15	<15	<15	<15	<15	22	29	28	15	<15	<15	<15	<15	<15	22	32	31	19	<15	<15	<15	<15	<15	23			
	353	30	31	<15	<15	<15	<15	<15	<15	23	32	35	20	<15	<15	<15	<15	<15	24	35	37	25	16	<15	<15	<15	<15	25			
160	217	28	28	<15	<15	<15	<15	<15	<15	22	31	31	19	<15	<15	<15	<15	<15	23	31	33	22	<15	<15	<15	<15	<15	24			
	362	31	33	20	<15	<15	<15	<15	<15	23	37	38	26	<15	<15	<15	<15	<15	26	38	40	30	18	16	<15	<15	<15	28			
	579	34	36	23	<15	<15	<15	<15	<15	25	40	42	30	18	<15	<15	<15	<15	29	42	44	36	23	20	<15	<15	<15	32			
200	339	32	30	<15	<15	<15	<15	<15	<15	23	36	33	19	<15	<15	<15	<15	<15	23	35	35	23	<15	<15	<15	<15	<15	24			
	565	35	34	20	<15	<15	<15	<15	<15	24	37	39	25	<15	<15	<15	<15	<15	26	41	42	31	16	<15	<15	<15	<15	29			
	904	40	40	24	<15	<15	<15	<15	<15	27	42	45	30	16	<15	<15	<15	<15	30	46	49	35	20	<15	<15	<15	<15	34			
250	530	23	26	17	<15	<15	<15	<15	<15	22	29	35	24	<15	<15	<15	<15	<15	24	40	38	27	16	<15	<15	<15	<15	26			
	883	35	34	21	<15	<15	<15	<15	<15	24	37	41	27	<15	<15	<15	<15	<15	27	42	45	34	18	<15	<15	<15	<15	31			
	1413	42	41	25	<15	<15	<15	<15	<15	27	45	48	30	17	<15	<15	<15	<15	33	47	52	36	22	15	<15	<15	<15	37			
315	841	30	31	18	<15	<15	<15	<15	<15	23	33	35	23	<15	<15	<15	<15	<15	24	39	39	27	15	<15	<15	<15	<15	26			
	1402	34	37	24	<15	<15	<15	<15	<15	25	40	41	28	<15	<15	<15	<15	<15	28	44	46	34	18	<15	<15	<15	<15	32			
	2243	42	41	28	<15	<15	<15	<15	<15	28	48	46	33	18	<15	<15	<15	<15	32	51	51	38	23	16	<15	<15	<15	37			
400	1356	31	37	22	<15	<15	<15	<15	<15	25	36	41	27	17	18	<15	<15	<15	28	38	44	34	23	23	18	<15	15	32			
	2261	39	41	28	17	16	<15	<15	<15	28	44	46	33	20	20	<15	<15	<15	32	47	49	37	25	25	20	<15	18	35			
	3617	45	46	32	20	18	<15	<15	<15	32	50	50	37	24	23	17	<15	<15	36	53	54	40	28	27	22	15	21	40			

Installation

Circular regulators are connected to a duct like a standard ventilation duct fitting. The regulator can be installed in horizontal, vertical or inclined mounted duct in a manner that the rotational axis of the dampe blade is always in a horizontal position. Also it is necessary to pay attention to the correct mounting direction shown with the air flow direction arrow on the regulator. Required length of the straight duct section is $L > 3 d$ before and $L > 1,5 d$ after the the regulator. If this lengths are smaller, deviations of the set flow rate can occure and the stated accuracy of the flow rate may not be achived; therefore, such installations are not recommended. Regulators are maintenance free.

