



DOCUMENTATION AIR HANDLING UNIT

Basic

PLUG-AND-PLAY,
INCLUDING CONTROL

Plug and play

BASIC



Figure 1.Basic

Plug-and-play air handling unit equipped with integrated control technology.

The Basic is the standardized version of the VKT air handling unit; for years, one of the top products of Orange Climate. The Basic is delivered as a standard coated indoor unit. An outdoor installation package is also available (including a roof, exhaust and intake hood). The unit is delivered in three functional sections, assembled as a single unit. Various options are available. This modular design provides additional flexibility in both configuration and future adjustments or upgrades.



Easily selectable through the online selection tool: tools.orangeclimate.com

Quality Standards



Features

- Modular and compact design
- Energy-efficient EC motors
- Fully integrated control with built-in control panel
- High-efficiency heat recovery via counterflow heat Exchanger (HR) or sorption heat wheel (W)
- Easy-to-replace filters
- Quick installation due to plug-and-play concept
- Standardly equipped with outside air damper
- Eurovent certified
- Equipped with energy label A/ A+
- Mechanical properties: in accordance with NEN-EN1886
- Easily selectable via online selection tool
- Compliant with ErP 2018 directive

Options

- Heating via hot water or electric
- Cooling via chilled water or DX
- DX heat pumps
- Change-over cooler/ heater
- Return air damper
- External display
- Overrun timer

Finish

- Visible parts RAL 7035
- Other RAL colors available upon request

Dimensions

- See schematic drawing

Types / Accessories

- Basic HR 10 - HR 100 - counterflow heat exchanger
- Basic W20 - W300 - heat wheel
- See schematic drawing Basic

Details

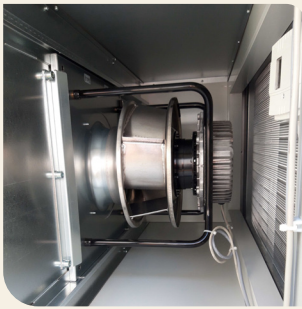

Figure 2. EC fan



Figure 3. Actuator for outside air damper



Figure 4. Control panel



Figure 5. External pressure differential sensor across the air intake filter

Configurations

Configuration 1: Basic HR indoor installation (left) Basic HR10 - Basic HR100

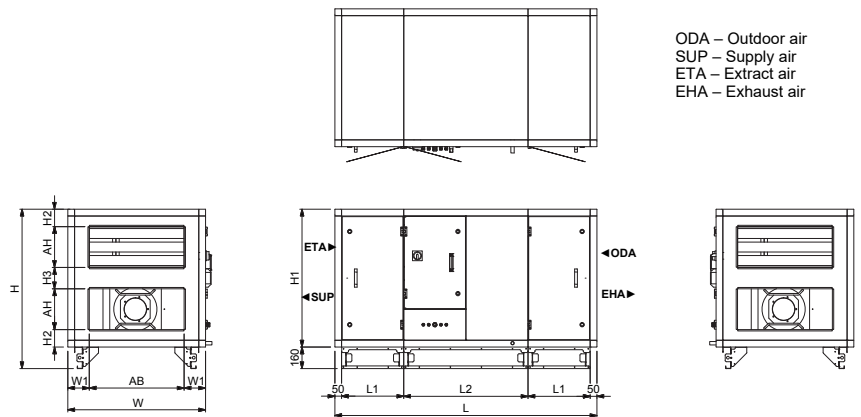

ODA – Outdoor air
SUP – Supply air
ETA – Extract air
EHA – Exhaust air

Indoor configuration	L [mm]	L1 [mm]	L2 [mm]	W [mm]	W1 [mm]	H [mm]	H1 [mm]	H2 [mm]	H3 [mm]	AW [mm]	AH [mm]	Weight [kg]
BASIC HR10	1940	460	920	560	155	1180	1020	130	160	250	300	280
BASIC HR20	1940	460	920	1020	160	1180	1020	130	160	700	300	370
BASIC HR30	1940	460	920	1020	160	1640	1480	195	290	700	400	480
BASIC HR40	1940	460	920	1480	190	1640	1480	145	190	1100	500	590
BASIC HR60	2630	690	1150	1710	155	1640	1480	145	190	1400	500	810
BASIC HR80	3090	920	1150	1940	170	2100	1940	160	220	1600	700	1150
BASIC HR100	3090	920	1150	2170	185	2100	1940	160	220	1800	700	1270

Configuration 2: Basic HR outdoor installation (right) Basic HR10 - Basic HR100

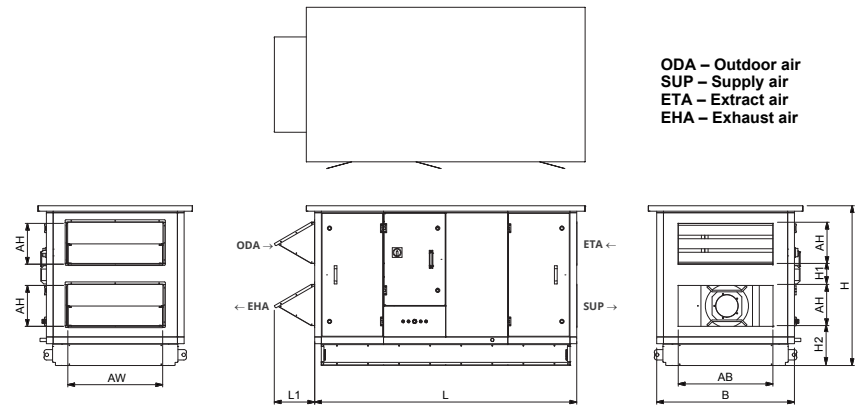

ODA – Outdoor air
SUP – Supply air
ETA – Extract air
EHA – Exhaust air

Outdoor configuration	L [mm]	W [mm]	H [mm]	AW [mm]	AH [mm]	L1 [mm]	H1 [mm]	H2 [mm]	Weight [kg]
BASIC HR10	1940	560	1180	250	300	300	160	290	300
BASIC HR20	1940	1020	1180	700	300	300	160	290	405
BASIC HR30	1940	1020	1640	700	400	400	290	355	515
BASIC HR40	1940	1480	1640	1100	500	500	190	305	640
BASIC HR60	2630	1710	1640	1400	500	240	190	305	930
BASIC HR80	3090	1940	2100	1600	700	340	220	320	1300
BASIC HR100	3090	2170	2100	1800	700	340	220	320	1430

Configuration 3: Basic W indoor installation (left) Basic W20 - Basic W100

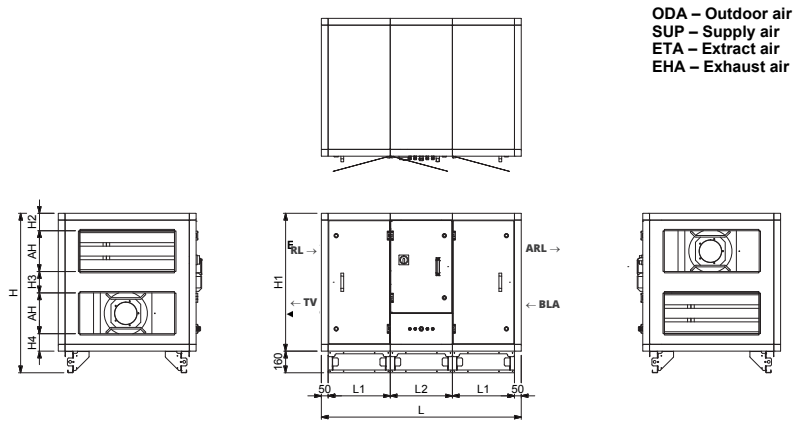

BASIC	L [mm]	L1 [mm]	L2 [mm]	W [mm]	W1 [mm]	H [mm]	H1 [mm]	H2 [mm]	H3 [mm]	H4 [mm]	AW [mm]	AH [mm]	Weight [kg]
BASIC W20	1480	460	460	1020	160	1180	1020	130	160	130	700	300	305
BASIC W30	1480	460	460	1250	175	1410	1250	187.5	275	187.5	900	300	415
BASIC W40	1480	460	460	1250	175	1640	1480	195	290	195	900	400	465
BASIC W60	1940	690	460	1480	190	1640	1480	145	190	145	1100	500	625
BASIC W80	2400	920	460	1710	255	1870	1710	145	305	260	1200	500	885
BASIC W100	2400	920	460	1940	170	2100	1940	160	220	160	1600	700	1085

Configuration 4: Basic W outdoor installation (right) Basic W20 - Basic W100

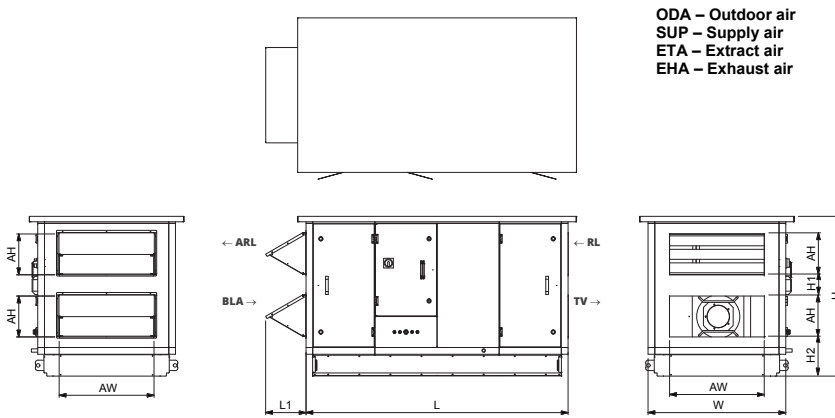

Outdoor configuration	L [mm]	W [mm]	H [mm]	AW [mm]	AH [mm]	L1 [mm]	H1 [mm]	H2 [mm]	Weight [kg]
BASIC W20	1480	1020	1180	700	300	300	160	290	330
BASIC W30	1480	1250	1410	900	300	385	175	347.5	445
BASIC W40	1480	1250	1640	900	400	385	290	355	505
BASIC W60	1940	1480	1640	1100	500	475	190	305	675
BASIC W80	2400	1710	1870	1200	500	475	305	420	955
BASIC W100	2400	1940	2100	1600	700	345	220	320	1165

Configuration 5: Basic W indoor installation (left) Basic W120 - Basic W300

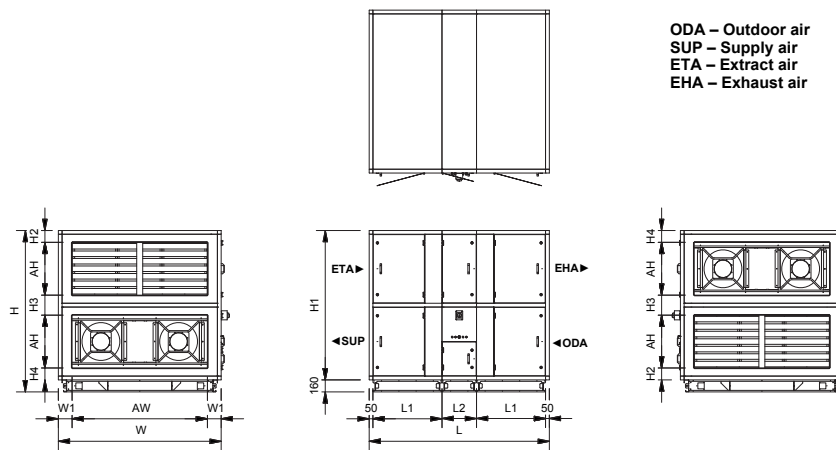

BASIC	L [mm]	L1 [mm]	L2 [mm]	W [mm]	W1 [mm]	H [mm]	H1 [mm]	H2 [mm]	H3 [mm]	H4 [mm]	AW [mm]	AH [mm]	Weight [kg]
BASIC W120	2400	920	460	2170	185	2150	1990	160	270	160	1800	700	1265
BASIC W160	2400	920	460	2170	185	2380	2220	275	385	160	1800	700	1440
BASIC W200	2400	920	460	2400	200	2380	2220	275	385	160	2000	700	1540
BASIC W240	2400	920	460	2630	215	2610	2450	175	300	175	2200	900	1830
BASIC W300	2400	920	460	2630	215	2840	2680	290	415	175	2200	900	1930

Configuration 6: Basic W outdoor installation (left) Basic W120 - Basic W300

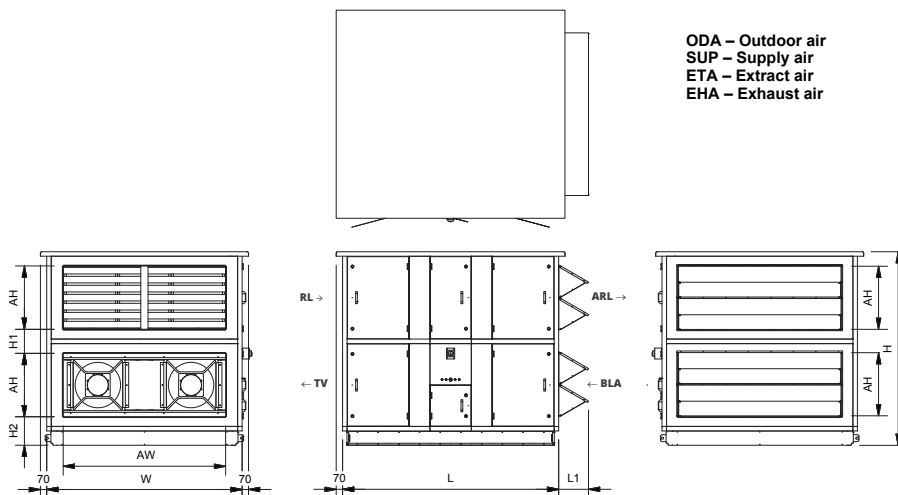

Outdoor configuration	L [mm]	W [mm]	H [mm]	AW [mm]	AH [mm]	L1 [mm]	H1 [mm]	H2 [mm]	Weight [kg]
BASIC W120	2400	2170	2150	1800	700	345	270	320	1425
BASIC W160	2400	2170	2380	1800	700	345	385	320	1600
BASIC W200	2400	2400	2380	2000	700	345	385	320	1720
BASIC W240	2400	2630	2610	2200	900	285	300	335	2045
BASIC W300	2400	2630	2840	2200	900	320	415	335	2160

Power Inverter Heat Pumps

The heat pumps are equipped with a Heat Interchanger Circuit (HIC) that ensures improved energy efficiency during cooling. The HIC-system redirects the fluid and converts it into gas, which is then returned to the system. This increases the pressure, reducing the effort required from the compressor to deliver the same cooling capacity. As a result, several benefits are achieved. Possibility for long duct lengths.

- Increased Seasonal Energy Efficiency Ratio (S.E.E.R.) and Seasonal Coefficient of Performance (S.C.O.P.) thanks to the use of HIC.
- Available in both 230V and 400V (type ZM 100 to 140).

The heat pumps are ideal for situations where energy efficiency and performance are crucial.

Configuration 7: Basic HR setup with coolers and heaters

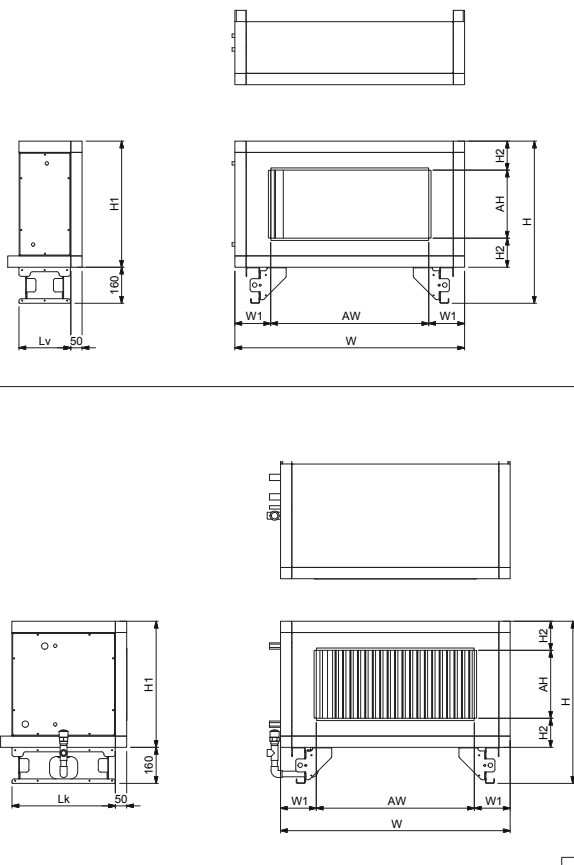
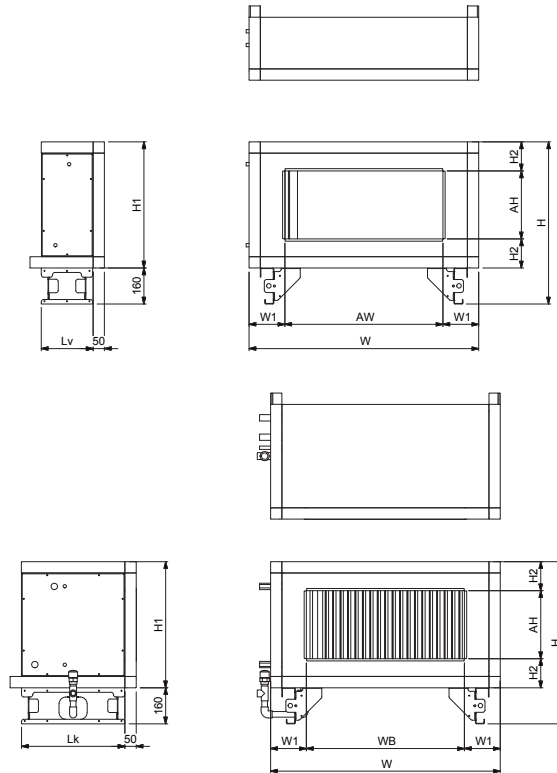

Figure 6. Basic setup with heat pumps

Weight	HR10	HR20	HR30	HR40
Casing	22 kg	28 kg	32 kg	37 kg
Reheater	5 kg	9 kg	11 kg	15 kg
Heater	8 kg	13 kg	17 kg	24 kg
Cooler	9 kg	15 kg	23 kg	32 kg
DX cooler	8 kg	14 kg	20 kg	28 kg

Outdoor configuration	Lv [mm]	Lk [mm]	W [mm]	W1 [mm]	H [mm]	H1 [mm]	H2 [mm]	AW [mm]	AH [mm]	0 D1 Heater	0 D2 Cooler	0 D2 DX Cooler	Heating capacity E-heater (kW)
BASIC HR10	230	460	560	155	720	560	130	250	300	15	28	16/ 22	4,5
BASIC HR20	230	460	1020	160	720	560	130	700	300	15	28	16/ 22	6
BASIC HR30	230	460	1020	160	950	790	195	700	400	28	28	16/ 22	10
BASIC HR40	230	460	1480	190	950	790	145	1100	500	28	28	16/ 22	12
BASIC HR60	230	460	1710	155	950	790	145	1400	500	28	35	22/ 28	20
BASIC HR80	230	460	1940	170	1180	1020	160	1600	700	28	35	22/ 28	24
BASIC HR100	230	460	2170	185	1180	1020	160	1800	700	28	35	22/ 35	30

Configuration 8: Basic W setup with coolers and heaters



Outside configuration	Lv [mm]	Lk [mm]	W [mm]	W1 [mm]	H [mm]	H1 [mm]	H2 [mm]	AW [mm]	AH [mm]	0 D1 Heater	0 D2 Cooler	0 D2 DX Cooler	Heating capacity E-heater (kW)
BASIC W20	230	460	1020	210	720	560	130	700	300	15	28	16/ 22	6
BASIC W30	230	460	1250	175	720	560	130	900	300	28	28	16/ 22	10
BASIC W40	230	460	1250	175	950	790	195	900	400	28	28	16/ 28	12
BASIC W60	230	460	1480	190	950	790	145	1100	500	28	35	22/ 28	20
BASIC W80	230	460	1710	255	1180	1020	260	1200	500	28	2"	22/ 35	24
BASIC W100	230	460	1940	170	1180	1020	160	1600	700	28	2"	22/ 42	30
BASIC W120	230	690	2170	185	1180	1020	160	1800	700	28	2"	22/ 35	30
BASIC W160	230	690	2170	185	1180	1020	160	1800	700	28	2"	22/ 42	On request
BASIC W200	230	690	2400	200	1180	1020	160	2000	700	28	2,5"	22/ 54	On request
BASIC W240	230	690	2630	215	1410	1250	175	2200	900	28	2,5"	22/ 35	On request
BASIC W300	230	690	2630	215	1410	1250	175	2200	900	28	2,5"	22/ 42	On request

Weight	W20	W30	W40	W60	W80	W100
Casing	28 kg	31 kg	34 kg	37 kg	44 kg	46 kg
Reheater	5 kg	10 kg	13 kg	15 kg	21 kg	23 kg
Heater	8 kg	15 kg	21 kg	26 kg	40 kg	43 kg
Cooler	9 kg	20 kg	29 kg	34 kg	49 kg	59 kg
DX cooler	8 kg	17 kg	24 kg	31 kg	44 kg	49 kg

Specification of electrical data for duct heater

Electric heater

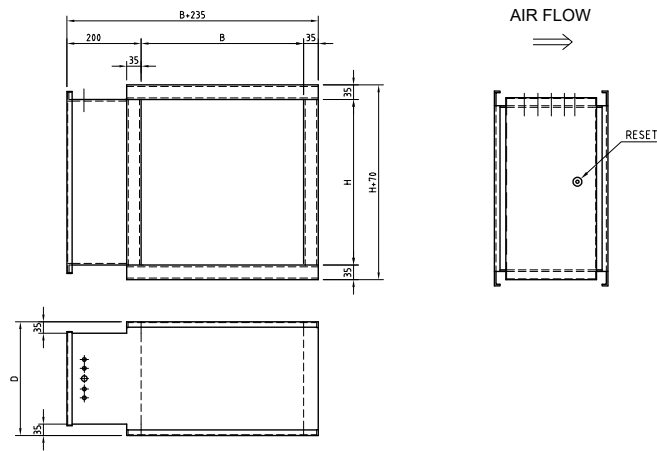

Basic	Version	Model	Duct size (mm)			Heater capacity (kW)	Power supply			Housing material	Ingress protection class	Electrical insulation	Exhaust air temperature
			Width (W)	Height (H)	Depth (D)		Voltage (V)	Phases (Ph)	Freq. (Hz)				
BASIC HR 10			250	300	370	4.5							
BASIC HR 20			700	300	370	6							
BASIC HR 30			700	400	370	10							
BASIC HR 40			1100	500	370	12							
BASIC W 20			700	300	370	6							
BASIC W 30			900	300	370	10							
BASIC W 40			900	400	370	12							
BASIC W 60			1100	500	500	20							
BASIC HR 60			1400	500	370	20							
BASIC W 80			1200	500	500	24							
BASIC HR 80			1600	700	370	24							
BASIC W 100			1600	700	500	30							
BASIC HR 100	VFL	MTXL	1800	700	500	30	400	3	50	Aluzink	IP43	NI	50 °C
BASIC HR 10			250	300	370	4.5							
BASIC HR 20			700	300	370	6							
BASIC HR 30			700	400	370	10							
BASIC HR 40			1100	500	370	12							
BASIC W 20			700	300	370	6							
BASIC W 30			900	300	370	10							
BASIC W 40			900	400	370	12							
BASIC W 60			1100	500	500	20							
BASIC HR 60			1400	500	370	20							
BASIC W 80			1200	500	500	24							
BASIC HR 80			1600	700	370	24							
BASIC W 100			1600	700	500	30							
BASIC HR 100			1800	700	500	30							

Schematic diagram of the control unit

- B1** Temperature sensor exhaust air
- B2** Temperature sensor supply air
- B3** Temperature sensor outside air intake
- B4** Temperature sensor plate heat exchanger / heat wheel
- B5** CO₂ sensor (optional)
- B6** Pressure sensor (optional)
- B7** Pressure sensor (optional)
- B8** Frost protection sensor heater
- P1** Pressure differential switch filter monitoring supply

- P2** Pressure differential switch filter monitoring return
- Y1** Three-way heating valve with actuator
- Y2** Three-way cooling valve with actuator
- Y3** Outside air intake damper
- Y4** Return air intake damper (optional)
- Y5** Modulating valve for bypass plate heat exchanger (Basic HR)
- M1** Supply fan
- M2** Return fan
- M3** Heating pump release

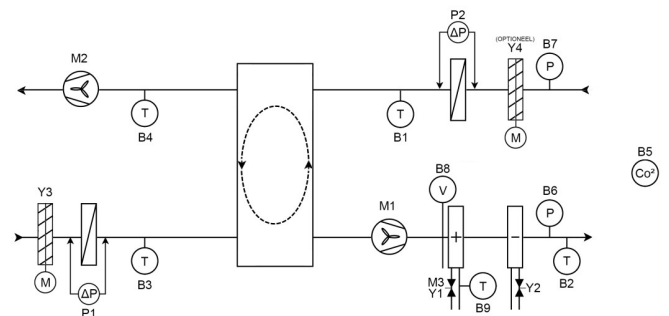
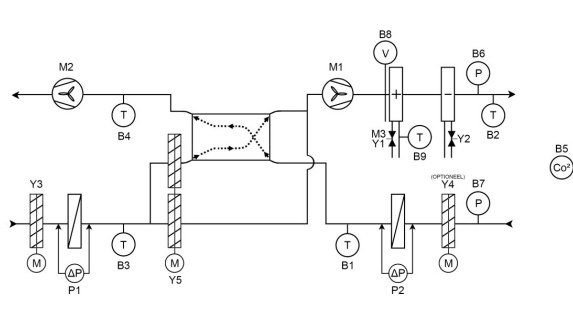

Connection data

Type	Voltage (V)	Maximum power (kW)	Trip value (A)
Basic HR10	1x230	1,5	20
Basic HR20	3x400	2,5	20
Basic HR30	3x400	4,5	20
Basic HR40	3x400	4,5	20
Basic HR60	3x400	7	20
Basic HR80	3x400	11	20
Basic HR100	3x400	11	20

Type	Voltage (V)	Maximum power (kW)	Trip value (A)
Basic W20	3x400	2,5	20
Basic W30	3x400	4,5	20
Basic W40	3x400	4,5	20
Basic W60	3x400	7	20
Basic W80	3x400	11	20
Basic W100	3x400	11	20
Basic W120	3x400	14	20
Basic W160	3x400	22	40
Basic W200	3x400	22	40
Basic W240	3x400	33	63
Basic W300	3x400	33	63

Range Basic unit

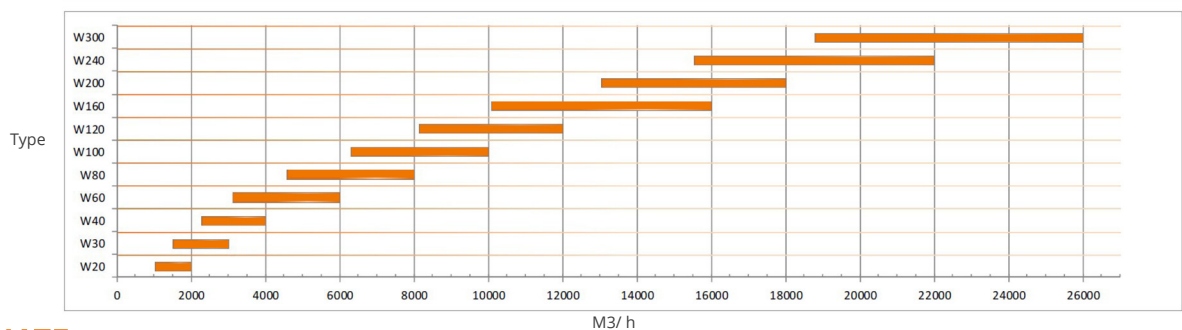
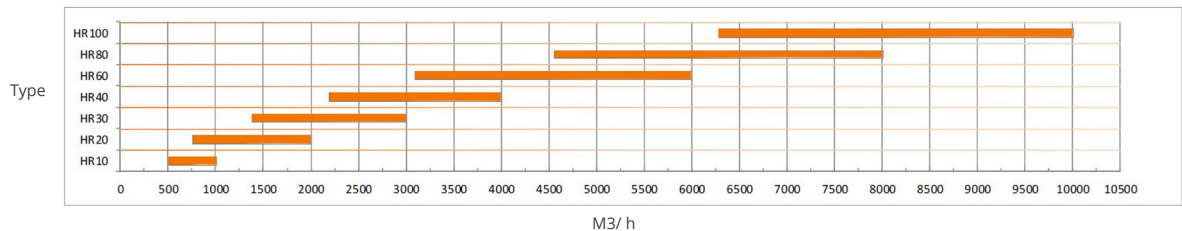

Order code

Fans	
F00	EC fans of the 3rd generation
F01	RadiPac C - 1st generation 2024
Heat exchangers	
X00	RSF+16-440-H-T-32 plate heat exchanger
X01	EM heat recovery wheel
X02	Future upgrade option
Air filtration	
A00	F7 / M5 configuration
A01	Future upgrade option
Cooling coils	
C00	No cooling coil
C01	Water cooling coil
C02	Cooling coil changeover
C03	DX cooling coil (1-circuit)
C04	DX change-over cooling coil (multiple circuits)
C05	DX change-over cooling coil (1-circuit)
C06	Cooling section without cooling coil
C07	Water cooling coil with an additional 1 row
Heating coils	
H00	No heating coil
H01	Water heating 1 row
H02	Electric heater
H03	Water heating 2 rows (up to size 100)
Air duct connection	
D00	Rigid air duct connection
D01	Flexible air duct connection
Dampers	
K00	Outdoor air damper (standard)
K01	Outdoor air and return air dampers
Electronics	
E00	No electronics (not available, reserved only)
E01	Electronics installed on terminal block (no control)
E02	OC Controls Regin
E03	OC Controls Carel
E04	Priva controls
Control system	
R00	Constant speed
R01	Constant volume
R02	Constant duct pressure
R03	Air quality (CO2) Space
R04	Air quality (CO2) Duct
Kleur	
RAL0000	No powder coating on housing
RALxxxx	Color of powder-coated casing (xxxx RAL code)
Heat pump	
W00	No heat pump
W01	Heat pump separately supplied
W02	Heat pump separately supplied
W03	Heat pump mounted on external frame, opposite side of control side, prefab installed
W04	Heat pump mounted on external frame, opposite side of control side, prefab installed
Version	
V01	Base version 01 (Current)
V02	Updated base version

Orange Climate

Climate systems are essential for a healthy and safe indoor environment. Good air quality in a building ensures that people feel comfortable and perform at their best. At Orange Climate, this is our focus. Our systems meet the highest standards in health, efficiency, and sustainability. But creating the perfect indoor climate goes beyond technology; it's about craftsmanship, trust, and the right people who listen and value relationships.

Our history

Merging Expertise and Tradition

The story of Orange Climate is unique, beginning in 2014 as a merger of historically renowned companies in the climate control sector. While the origins of Orange Climate itself date back to 2014, the roots of the constituent companies go much further back in time. Waterloo Register Co. Inc., founded in 1902 in America, and Waterloo Grille Company Limited, established in 1945

in England, laid an early foundation for what would later become part of Orange Climate. The Dutch branch of Waterloo was founded in 1970. All of this formed a rich background of expertise and experience.

A significant development occurred when Verhulst, founded in 1820 in the Netherlands, was acquired by Econosto in 1996 and later by a large family business in 2005. This led to the establishment of Verhulst Agri and Verhulst Renovation and Maintenance, and the launch of Autarkis in 2006. The real transformation came with the founding of Orange Climate in 2014, bringing all these entities together under one roof. The group continued to expand with the establishment of OC Waterloo Middle East in 2018 in the United Arab Emirates, the acquisition of Airosonic in 2018, IMP Klima in 2020 in Slovenia, and finally Inteco in 2022 in the Netherlands.





OC IMP KLIMA
Godovič 150
SI-5275 Godovič
Slovenia
oc-impklima.com